

Ref.: UP30A-NAC-MMA

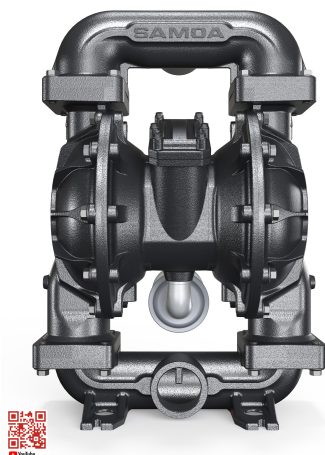

3" PNEUMATIC DOUBLE DIAPHRAGM PUMP, UP30, PIVOT SERIES, ALUMINIUM-ALUMINIUM-SANTOPRENE-SANTOPRENE, NPT-CENTRAL-THREATED

Air operated double diaphragm pumps for dosing, spraying, transferring, evacuating and distributing a wide variety of fluids. SAMOA offers a wide range of material options for chemical compatibility and to withstand abrasion, temperature and fatigue caused by demanding conditions. UP30 pump makes the difference through:

- HIGHER EFFICIENCY. Maximum fluid flow with reduced air consumption.
- INCREASED RELIABILITY. No stall, no icing, reliable start-up and longer air valve and diaphragm lifes.
- MAXIMUM VERSATILITY. Metal pumps and a wide range of diaphragms, seats and balls offer broad fluid and application compatibility.
- EASY SERVICING. Simplified maintenance and cleaning. Components designed for long life and reliability. This model is a fully groundable ATEX certified pump, for use in potentially explosive atmospheres (Ex II2 GD IIB/IIC 95 °C). Instruction books: 855871 and 855865.

Technical data

Documentation

More information

Pump size	3"
Pressure ratio	1:1
Target product type	Pivot Series Diaphragm Pumps
Maximum free flow delivery	1000 l/min (264 gal/min)
Air pressure operating range	1,5-8 bar (20-120 psi)
Solids in suspension maximum size	12,7 mm (0,5 ")
Maximum dry suction head	6 m (20 ft)
Maximum wet suction head	8 m (26 ft)
Delivery per cycle	10 l (2,6 gal)
Fluid inlet	3" NPT (F)
Fluid outlet	3" NPT (F)
Air inlet	3/4" NPT (F)
Air exhaust port	1 1/2" NPT (F)
Sound level	83 dB
Certification	ATEX
Central body & Air chambers material	Aluminium
Fluid ports / Location	3" NPT central threaded
Fluid chambers & Manifolds material	Aluminium
Hardware Bolts & Inserts material	Carbon steel
Diaphragms type & material	Santoprene
Valve seats material	Santoprene

Valve balls material	Santoprene
Wetted materials	Aluminium, Santoprene
Accessories for UE Pumps	No
Weight	64 kg (141 lb)

[Technical data](#)

[Documentation](#)

[More information](#)

Instruction manuals

855864 Instruction book: Pneumatic double diaphragm pumps, DF30, DF50, DF100, DirectFlo series, Externally driven versions (PDF)

[Download](#)

855871 Instruction book: 3" pneumatic double diaphragm pump, UP30, Pivot series, metallic versions (PDF)

[Download](#)

Catalogs

Product brochure: AODDP, UP30 METAL, 2023 EN (PDF)

[Download](#)

[Technical data](#)

[Documentation](#)

[More information](#)

Performance charts with water at room temperature (20 °C - 70 °F)

