

# High Volume Pro Gun

## Operations Manual

This manual is applicable to the following models:

- 58100-1-X
- 58104-1
- 58105-1
- 58107-1
- 60625-1
- 60625-1-INT
- CPHV-1000
- CPHV-1000-EP
- HVPRO-2000-A
- CHPV-2000

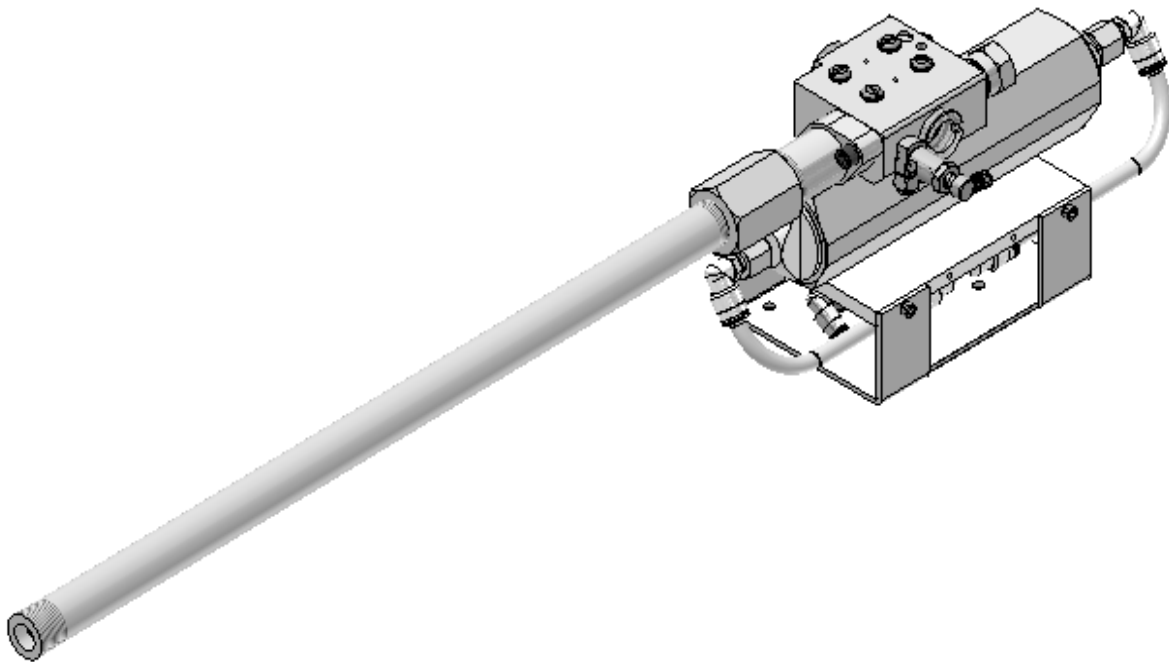



**CORPORATE HEADQUARTERS**

**2030 Falling Waters Rd, Suite 350, Knoxville, TN 37922 · USA · Tel: (865) 686-5670**

**DISTRIBUTION AND PURCHASING**

**642 Barbrow Ln, Knoxville, TN 37932 · USA · Tel: (865) 684-4416**

**TECHNOLOGY CENTER AND MANUFACTURING**

**1862 Ives Ave, Kent, WA 98032 · USA · Tel (253) 854-2660 · Fax (253) 854-1666**

E-mail: [info@mvpind.com](mailto:info@mvpind.com)

For a list of international distributors, visit our website at :

[www.mvpind.com/mvp-international](http://www.mvpind.com/mvp-international)

*Use of this product confirms that Magnum Venus Products, Inc.'s standard terms and conditions of sale apply.*

# **Table of Contents**

<b>Section</b>	<b>Page</b>
• <b>Table of Contents</b>	<b>3</b>
• <b>Safety &amp; Warning Information</b>	<b>4</b>
• <b>Introduction</b>	<b>15</b>
• <b>Getting Started</b>	<b>16</b>
• <b>Disassembling the Gun</b>	<b>18</b>
• <b>Reassembling Gun Block</b>	<b>23</b>
• <b>Rebuilding the Actuator</b>	<b>28</b>
• <b>Assembling Components</b>	<b>29</b>
• <b>Specifications</b>	<b>30</b>
• <b>Parts Drawings</b>	<b>32</b>

# Safety & Warning Information

## Warnings

Due to the vast number of chemicals that could be used and their varying chemical reactions, the buyer and user of this equipment should determine all factors relating to the fluids used, including any of the potential hazards involved. Particular inquiry and investigation should be made into potential dangers relating to toxic fumes, fires, explosions, reaction times, and exposure of human beings to the individual components or their resultant mixtures. MVP assumes no responsibility for loss, damage, expense or claims for bodily injury or property damage, direct or consequential, arising from the use of such chemical components.

The end user is responsible for ensuring that the end product or system complies with all the relevant laws in the country where it is to be used and that all documentation is adhered to.

### Recommended Occupational Safety & Health Act (OSHA) Documentation:

- 1910.94                      Pertaining to ventilation
- 1910.106                    Pertaining to flammable liquids
- 1910.107                    Pertaining to spray finishing operations, particularly paragraph (m), Organic Peroxides and Dual Component Coatings







For Additional information, contact the Occupational Safety and Health Administration (OSHA) at <https://www.osha.gov/about.html>.

### Recommended National Fire Protection Association (NFPA) Documentation:

- NFPA No.33 Chapter 14                      Organic Peroxides and Dual Component Materials
- NFPA No. 63                                  Dust Explosion Prevention
- NFPA No. 70                                  National Electrical Code
- NFPA No. 77                                  Static Electricity
- NFPA No. 91                                  Blower and Exhaust System
- NFPA No. 654                                  Plastics Industry Dust Hazards

**Fire Extinguisher** – code ABC, rating number 4a60bc using Extinguishing Media –Foam, Carbon Dioxide, Dry Chemical, Water Fog, is recommended for this product and applications.

The following general warnings and guidelines are for the setup, use, grounding, maintenance, and repair of equipment. Additional product-specific warnings may be found throughout this manual as applicable. Please contact your nearest MVP Technical Service Representative if additional information is needed.

<b>Safety Precautions</b>
<ul style="list-style-type: none"> <li>• Avoid skin contact and inhalation of all chemicals.</li> </ul>
<ul style="list-style-type: none"> <li>• Review Material Safety Data Sheet (MSDS) to promote the safe handling of chemicals in use.</li> </ul>
<ul style="list-style-type: none"> <li>• Restrict the use of all chemicals to designated areas with good ventilation.</li> </ul>
<ul style="list-style-type: none"> <li>• Chemicals are flammable and reactive.</li> </ul>
<ul style="list-style-type: none"> <li>• Noxious fumes released when combusted.</li> </ul>
<ul style="list-style-type: none"> <li>• Operate equipment in a ventilated environment only.</li> </ul>
<ul style="list-style-type: none"> <li>• Uncured liquid resins are highly flammable unless specifically labeled otherwise.</li> </ul>
<ul style="list-style-type: none"> <li>• Cured laminate, accumulations of overspray, and laminate sandings are highly combustible.</li> </ul>
<ul style="list-style-type: none"> <li>• Do not operate or move electrical equipment when flammable fumes are present.</li> </ul>
<ul style="list-style-type: none"> <li>• Ground all equipment.</li> </ul>
<ul style="list-style-type: none"> <li>• If a spark is seen or felt, immediately halt operation. Do not operate the equipment until the issue has been identified and repaired.</li> </ul>
<ul style="list-style-type: none"> <li>• Contaminated catalyst may cause fire or explosion.</li> </ul>
<ul style="list-style-type: none"> <li>• Containers may explode if exposed to fire / heat.</li> </ul>
<ul style="list-style-type: none"> <li>• Use and store chemicals away from heat, flames, and sparks.</li> </ul>
<ul style="list-style-type: none"> <li>• Do not smoke in work areas or near stored chemicals.</li> </ul>
<ul style="list-style-type: none"> <li>• Do not mix Methyl Ethyl Ketone Peroxide (MEKP) with materials other than polyethylene.</li> </ul>
<ul style="list-style-type: none"> <li>• Do not dilute MEKP.</li> </ul>
<ul style="list-style-type: none"> <li>• Keep food and drink away from work area.</li> </ul>
<div style="display: flex; justify-content: space-around; align-items: center;"> <div style="text-align: center;">  <p><b>CORROSIVE</b></p> </div> <div style="text-align: center;">  <p><b>FLAMMABLE</b></p> </div> <div style="text-align: center;">  <p><b>GROUNDING</b></p> </div> <div style="text-align: center;">  <p><b>EXPLOSIVE</b></p> </div> <div style="text-align: center;">  <p><b>DANGER</b></p> </div> <div style="text-align: center;">  <p><b>DANGER</b></p> </div> </div>

**Physical Hazards**

- Never look directly into the spray gun fluid tip. Serious injury or death can result.
- Never aim the spray gun at or near another person. Serious injury or death can result.
- Chemical compounds can be severely irritating to the eyes and skin.
- Inhalation, ingestion, or injection may damage internal organs and lead to pulmonary disorders, cancers, lymphomas, and other diseases or health conditions.
- Other potential health effects include: irritation of the eyes and upper respiratory tract, headache, light-headedness, dizziness, confusion, drowsiness, nausea, vomiting, and occasionally abdominal pain.
- Eye contact: Immediately flush with water for at least 15 minutes and seek immediate medical attention.
- Skin Contact: Immediately wash with soap and water and seek immediate medical attention.
- Inhalation: Move the person to fresh air and seek immediate medical attention.
- Do not remove shields, covers, or safety features on equipment that is in use.
- Never place fingers, hands, or any body part near or directly in front of the spray gun fluid tip. The force of the liquid as it exits the spray tip can shoot liquid through the skin.
- Keep hands and body parts away from any moving equipment or components.
- Do not stand under plunger
- An improperly loaded drum may lead to an imbalance, causing a unit to tip over

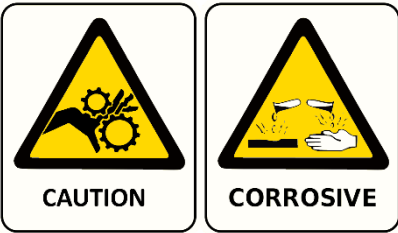

**Personal Protective Equipment (PPE)**

- MVP recommends the use of personal safety equipment with all products in our catalog.
- Wear safety goggles, hearing protection, a respirator, and chemical resistant gloves.
- Wear long sleeve shirts or jackets and pants to minimize skin exposure.
- PPE should be worn by operators and service technicians to reduce the risk of injury.



For Additional information, contact the Occupational Safety and Health Administration (OSHA). <https://www.osha.gov/about.html>

## Symbol Definitions



Indicates the risk of contact with chemicals that are hazardous, which may lead to injury or death.



Indicates the risk of contact with voltage / amperage that may lead to serious injury or death.



Indicates that the materials being used are susceptible to combustion.



Indicates the risk of contact with moving components that may lead to serious injury or death.



Indicates that the system or component should be grounded before proceeding with use or repair.



Indicates the use of lit cigarettes or cigars is prohibited, because the materials being used are susceptible to combustion.



Indicates that the materials and/or the process being performed can lead to ignition and explosion.



A recommendation for the use of Personal Protective Equipment (PPE) before using or repairing the product.

## Polymer Matrix Materials: Advanced Composites

Potential health hazards associated with the use of advanced composites can be controlled through the implementation of an effective industrial hygiene and safety program.

[https://www.osha.gov/dts/osta/otm/otm\\_iii/otm\\_iii\\_1.html#t\\_iii:1\\_1](https://www.osha.gov/dts/osta/otm/otm_iii/otm_iii_1.html#t_iii:1_1)

<b>Resins</b>		
<b>Composite Component</b>	<b>Organ System Target (Possible Target)</b>	<b>Known (Possible) Health Effect</b>
Epoxy resins	Skin, lungs, eyes	Contact and allergic dermatitis, conjunctivitis
Polyurethane resins	Lungs, skin, eyes	Respiratory sensitization, contact dermatitis, conjunctivitis
Phenol formaldehyde	Skin, lungs, eyes	As above (potential carcinogen)
Bismaleimides (BMI)	Skin, lungs, eyes	As above (potential carcinogen)
Polyamides	Skin, lungs, eyes	As above (potential carcinogen)
<b>Reinforcing materials</b>		
<b>Composite Component</b>	<b>Organ System Target (Possible Target)</b>	<b>Known (Possible) Health Effect</b>
Aramid fibers	Skin (lungs)	Skin and respiratory irritation, contact dermatitis (chronic interstitial lung disease)
Carbon/graphite fibers	Skin (lungs)	As noted for aramid fibers
Glass fibers (continuous filament)	Skin (lungs)	As noted for aramid fibers
<b>Hardeners and curing agents</b>		
<b>Composite Component</b>	<b>Organ System Target (Possible Target)</b>	<b>Known (Possible) Health Effect</b>
Diaminodiphenylsulfone	N/A	No known effects with workplace exposure
Methylenedianiline	Liver, skin	Hepatotoxicity, suspect human carcinogen
<b>Other aromatic amines</b>		
<b>Composite Component</b>	<b>Organ System Target (Possible Target)</b>	<b>Known (Possible) Health Effect</b>
Meta-phenylenediamine (MPDA)	Liver, skin (kidney, bladder)	Hepatitis, contact dermatitis (kidney and bladder cancer)
Aliphatic and cyclo-aliphatic amines	Eyes, skin	Severe irritation, contact dermatitis
Polyaminoamide	Eyes, skin	Irritation (sensitization)
Anhydride	Eyes, lungs, skin	Severe eye and skin irritation, respiratory sensitization, contact dermatitis

## Catalyst - Methyl Ethyl Ketone Peroxide (MEKP)

MEKP is among the more hazardous materials found in commercial channels. The safe handling of the “unstable (reactive)” chemicals presents a definite challenge to the plastics industry. The highly reactive property which makes MEKP valuable to the plastics industry in producing the curing reaction of polyester resins also produces the hazards which require great care and caution in its storage, transportation, handling, processing and disposal. MEKP is a single chemical. Various polymeric forms may exist which are more or less hazardous with respect to each other. These differences may arise not only from different molecular structures (all are, nevertheless, called “MEKP”) and from possible trace impurities left from the manufacture of the chemicals, but may also arise by contamination of MEKP with other materials in its storage or use. Even a small amount of contamination with acetone, for instance, may produce an extremely shock-sensitive and explosive compound.



### **WARNING**

***Contamination with promoters, materials containing promoters (such as laminate sandings), or with any readily oxidizing material (such as brass or iron) will cause exothermic redox reactions which can be explosive in nature. Heat applied to MEKP or heat buildup from contamination reactions can cause the material to reach its Self-Accelerating Decomposition Temperature (SADT).***

Researchers have reported measuring pressure rates-of-rise well over 100,000 psi per second when certain MEKP's reach their SADT. For comparison, the highest-pressure rate-of-rise listed in NFPA Bulletin NO.68, “Explosion Venting”, is 12,000 psi per second for an explosion of 12% acetylene and air. The maximum value listed for a hydrogen explosion is 10,000 psi per second. Some forms of MEKP, if allowed to reach their SADT, will burst even an open topped container. This suggests that it is not possible to design a relief valve to vent this order of magnitude of pressure rate-of-rise. The user should be aware that any closed container, be it a pressure vessel, surge chamber, or pressure accumulator, could explode under certain conditions. There is no engineering substitute for care by the user in handling organic peroxide catalysts. If, at any time, the pressure relieve valve on top of the catalyst tank should vent, the area should be evacuated at once and the fire department called. The venting could be the first indication of a heat, and therefore, pressure build-up that could eventually lead to an explosion. Moreover, if a catalyst tank is sufficiently full when the pressure relief valve vents, some catalyst may spray out, which could cause eye injury. For this reason, and many others, anyone whose job puts them in an area where this vented spray might go, should always wear full eye protection even when laminating operations are not taking place.

Safety in handling MEKP depends to a great extent on employee education, proper safety instructions, and safe use of the chemicals and equipment. Workers should be thoroughly informed of the hazards that may result from improper handling of MEKP, especially regarding contamination, heat, friction and impact. They should be thoroughly instructed regarding the proper action to be taken in the storage, use, and disposal of MEKP and other hazardous materials used in the laminating operation. In addition, users should make every effort to:

- Store MEKP in a cool, dry place in original containers away from direct sunlight and away from other chemicals.
- Keep MEKP away from heat, sparks, and open flames.
- Prevent contamination or MEKP with other materials, including polyester over spray and sandings, polymerization accelerators and promoters, brass, aluminum, and non-stainless steels.

- Never add MEKP to anything that is hot, since explosive decomposition may result.
- Avoid contact with skin, eyes, and clothing. Protective equipment should be worn at all times. During clean-up of spilled MEKP, personal safety equipment, gloves, and eye protection must be worn. Firefighting equipment should be at hand and ready.
- Avoid spillage, which can heat up to the point of self-ignition.
- Repair any leaks discovered in the catalyst system immediately, and clean-up the leaked catalyst at once in accordance with the catalyst manufacturer's instructions.
- Use only original equipment or equivalent parts from Magnum Venus Products in the catalyst system (i.e.: hoses, fitting, etc.) because a dangerous chemical reaction may result between substituted parts and MEKP.
- Catalyst accumulated from the purging of hoses or the measurement of fluid output deliveries should never be returned to the supply tank, such catalyst should be diluted with copious quantities of clean water and disposed of in accordance with the catalyst manufacturer's instructions.

The extent to which the user is successful in accomplishing these ends and any additional recommendations by the catalyst manufacturer determines largely the safety that will be present in his operation.

## Clean-Up Solvents and Resin Diluents



### **WARNING**

***A hazardous situation may be present in your pressurized fluid system! Hydro carbon solvents can cause an explosion when used with aluminum or galvanized components in a closed (pressurized) fluid system (pump, heaters, filters, valves, spray guns, tanks, etc.). An explosion could cause serious injury, death, and/or substantial property damage. Cleaning agents, coatings, paints, etc. may contain Halogenated Hydrocarbon solvents. Some Magnum Venus Products spray equipment includes aluminum or galvanized components and will be affected by Halogenated Hydrocarbon solvents.***

There are three key elements to the Halogenated Hydrocarbon (HHC) solvent hazard.

- |    |   |  |
|----|---|--|
| 1. | The presence of HHC solvents.               | 1,1,1 – Trichloroethane and Methylene Chloride are the most common of these solvents. However, other HHC solvents are suspect if used; either as part of paint or adhesives formulation, or for clean-up flushing.   |
| 2. | Aluminum or Galvanized Parts.               | Most handling equipment contains these elements. In contact with these metals, HHC solvents could generate a corrosive reaction of a catalytic nature.   |
| 3. | Equipment capable of withstanding pressure. | When HHC solvent contact aluminum or galvanized parts inside a closed container such as a pump, spray gun, or fluid handling system, the chemical reaction can, over time, result in a build-up of heat and pressure, which can reach explosive proportions. When all three elements are present, the result can be an extremely violent explosion. The reaction can be sustained with very little aluminum or galvanized metal; any amount of aluminum is too much. |

- The reaction is unpredictable. Prior use of an HHC solvent without incident (corrosion or explosion) does NOT mean that such use is safe. These solvents can be dangerous alone (as a clean-up or flushing agent) or when used as a component or a coating material. There is no known inhibitor that is effective under all circumstances. Mixing HHC solvents with other materials or solvents such as MEKP, alcohol, or toluene may render the inhibitors ineffective.
- The use of reclaimed solvents is particularly hazardous. Reclaimers may not add any inhibitors. The possible presence of water in reclaimed solvents could also feed the reaction.
- Anodized or other oxide coatings cannot be relied upon to prevent the explosive reaction. Such coatings can be worn, cracked, scratched, or too thin to prevent contact. There is no known way to make oxide coatings or to employ aluminum alloys to safely prevent the chemical reaction under all circumstances.
- Several solvent suppliers have recently begun promoting HHC solvents for use in coating systems. The increasing use of HHC solvents is increasing the risk. Because of their exemption from many state implementation plans as Volatile Organic Compounds (VOCs), their low flammability hazard, and their not being classified as toxic or carcinogenic substances, HHC solvents are very desirable in many respects.



**WARNING**

***Do not use Halogenated Hydrocarbon (HHC) solvents in pressurized fluid systems having aluminum or galvanized wetted parts. Magnum Venus Products is aware of NO stabilizers available to prevent HHC solvents from reaction under all conditions with aluminum components in closed fluid systems. HHC solvents are dangerous when used with aluminum components in a closed fluid system.***

- Consult your material supplier to determine whether your solvent or coating contains Halogenated Hydrocarbon solvents.
- Magnum Venus Products recommends that you contact your solvent supplier regarding the best non-flammable clean-up solvent with the heat toxicity for your application.
- If, however, you find it necessary to use flammable solvents, they must be kept in approved, electrically grounded containers.
- Bulk solvent should be stored in a well-ventilated, separate building, 50 feet away from your main plant.
- You should only allow enough solvent for one day's use in your laminating area.
- NO SMOKING signs must be posted and observed in all areas of storage or where solvents and other flammable materials are used.
- Adequate ventilation (as covered in OSHA Section 1910.94 and NFPA No.91) is important wherever solvents are stored or used, to minimize, confine and exhaust the solvent vapors.
- Solvents should be handled in accordance with OSHA Section 1910.106 and 1910.107.

## Catalyst Diluents

Magnum Venus Products spray-up and gel-coat systems currently produced are designed so that catalyst diluents are not required. Magnum Venus Products therefore recommends that diluents not be used to avoid possible contamination which could lead to an explosion due to the handling and mixing of MEKP and diluents. In addition, it eliminates any problems from the diluent being contaminated through rust particles in drums, poor quality control on the part of the diluents suppliers, or any other reason. If diluents are absolutely required, contact your catalyst supplier and follow his instructions explicitly. Preferably the supplier should premix the catalyst to prevent possible “on the job” contamination while mixing.



### **WARNING**

***If diluents are not used, remember that catalyst spillage and gun, hose, and packing leaks are potentially more hazardous since each drop contains a higher concentration of catalyst and will therefore react more quickly with overspray and the leak.***

## Cured Laminate, Overspray and Laminate Sandings Accumulation

- Remove all accumulations of overspray, Fiberglass Reinforced Plastic (FRP) sandings, etc. from the building as they occur. If this waste is allowed to build up, spillage of catalyst is more likely to start a fire; in addition, the fire would burn hotter and longer.
- Floor coverings, if used, should be non-combustible.
- Spilled or leaked catalyst may cause a fire if it comes in contact with an FRP product, oversprayed chop or resin, FRP sandings or any other material with MEKP.

To prevent spillage and leakage, you should:

- |  |   |
|--|---|
| 1. Maintain your Magnum Venus Products System.   | Check the gun several times daily for catalyst and resin packing or valve leaks. REPAIR ALL LEAKS IMMEDIATELY.  |
| 2. Never leave the gun hanging over or lying inside the mold.  | A catalyst leak in this situation would certainly damage the part, possibly the mold, and may cause a fire.   |
| 3. Inspect resin and catalyst hoses daily for wear or stress at the entry and exits of the boom sections and at the hose and fittings. | Replace if wear or weakness is evident or suspected.  |
| 4. Arrange the hoses and fiberglass roving guides so that the fiberglass strands DO NOT rub against any of the hoses at any point.     | If allowed to rub, the hose will be cut through, causing a hazardous leakage of material which could increase the danger of fire. Also, the material may spew onto personnel in the area. |

## Toxicity of Chemicals

- Magnum Venus Products recommends that you consult OSHA Sections 1910.94, 1910.106, 1910.107 and NFPA No.33, Chapter 14, and NFPA No.91.
- Contact your chemical supplier(s) and determine the toxicity of the various chemicals used as well as the best methods to prevent injury, irritation and danger to personnel.
- Also determine the best methods of first aid treatment for each chemical used in your plant.

## Equipment Safety

Magnum Venus Products suggest that personal safety equipment such as EYE GOGGLES, GLOVES, EAR PROTECTION, and RESPIRATORS be worn when servicing or operating this equipment. Ear protection should be worn when operating a fiberglass chopper to protect against hearing loss since noise levels can be as high as 116 dB (decibels). This equipment should only be operated or serviced by technically trained personnel!



### CAUTION

***Never place fingers, hands, or any body part near or directly in front of the spray gun fluid tip. The force of the liquid as it exits the spray tip can cause serious injury by shooting liquid through the skin. NEVER LOOK DIRECTLY INTO THE GUN SPRAY TIP OR POINT THE GUN AT OR NEAR ANOTHER PERSON.***



### DANGER

***Contaminated catalyst may cause fire or explosion. Before working on the catalyst pump or catalyst accumulator, wash hands and tools thoroughly. Be sure work area is free from dirt, grease, or resin. Clean catalyst system components with clean water daily.***



### DANGER

***Eye, skin, and respiration hazard. The catalyst MEKP may cause blindness, skin irritation, or breathing difficulty. Keep hands away from face. Keep food and drink away from work area.***

## Treatment of Chemical Injuries



### CAUTION

***Refer to your catalyst manufacturer's safety information regarding the safe handling and storage of catalyst. Wear appropriate safety equipment as recommended.***

Great care should be used in handling the chemicals (resins, catalyst and solvents) used in polyester systems. Such chemicals should be treated as if they hurt your skin and eyes and as if they are poison to your body. For this reason, Magnum Venus Products recommends the use of protective clothing and eye wear in using polyester systems. However, users should be prepared in the event of such an injury.

**Precautions include:**

1. Know precisely what chemicals you are using and obtain information from your chemical supplier on what to do in the event the chemical gets onto your skin or into the eyes, or if swallowed.
2. Keep this information together and easily available so that it may be used by those administering first aid or treating the injured person.
3. Be sure the information from your chemical supplier includes instructions on how to treat any toxic effects the chemicals have.

**WARNING**

**Contact your doctor immediately in the event of an injury. If the product's MSDS includes first aid instructions, administer first aid immediately after contacting a doctor.**

Fast treatment of the outer skin and eyes that contact chemicals generally includes immediate and thorough washing of the exposed skin and immediate and continuous flushing of the eyes with lots of clean water for at least 15 minutes or more. These general instructions of first aid treatment may be incorrect for some chemicals; you must know the chemicals and treatment before an accident occurs. Treatment for swallowing a chemical frequently depends upon the nature of the chemical.

**Emergency Stop Procedure**

In an emergency, follow these steps to stop a UPS System:

1. The ball valve located where the air enters the power head of the resin pump, should be moved to the "OFF" or closed position.

**Note**     **The "open" or "on" position is when the ball valve handle is parallel (in line) with the ball valve body. The "closed" or "off" position is when the ball valve handle is perpendicular (across) the ball valve body.**

2. Turn all system regulators to the "OFF" position (counter-clockwise) position.
3. Verify / secure the catalyst relief line, located on the catalyst relief valve.
4. Verify / secure the resin return line, located on the resin filter.
5. Place a container under the resin pump ball valve to catch ejected resin.
6. Locate the ball valve on the resin pump.
7. Rotate the ball valve 90 degrees to the "On" or open position.

**Grounding**

Grounding an object means providing an adequate path for the flow of the electrical charge from the object to the ground. An adequate path is one that permits charge to flow from the object fast enough that it will not accumulate to the extent that a spark can be formed. It is not possible to define exactly what will be an adequate path under all conditions since it depends on many variables. In any event, the grounding means should have the lowest possible electrical resistance.

Grounding straps should be installed on all loose conductive objects in the spraying area. This includes material containers and equipment. Magnum Venus Products recommends grounding straps be made of AWG No.18 stranded wire as a minimum and the larger wire be used where possible. NFPA Bulletin No77 states that the electrical resistance of such a leakage path may be as low as 1 meg ohm (10 ohms) but that resistance as high as 10,000 meg ohms will produce an adequate leakage path in some cases.

**CAUTION**



***Whenever flammable or combustible liquids are transferred from one container to another, or from one container to the equipment, both containers or container and equipment shall be effectively bonded and grounded to dissipate static electricity. For further information, see National Fire Protection Association (NFPA) 77, titled “Recommended Practice on Static Electrical”. Refer especially to section 7-7 titled “Spray Application of Flammable and Combustible Materials”.***

## Introduction

This manual provides information for the operation, maintenance, and simple repair of the MVP High Volume Pro Gun. The following procedures are included:

- Step-by-step assembly and disassembly for each component
- Component specifications



Please read this manual carefully and retain for future reference. Follow the steps in the order given, otherwise you may damage the equipment or injure yourself.

The gun will not need to be completely disassembled for daily cleaning, however the entire gun should be disassembled and the O-rings and seals replaced approximately every six months. The gun breaks down into two separate modules which can then be disassembled further into their individual parts. A special tool kit, including a specially designed Pro Gun tool and packing assembly tool, is available to aid in performing maintenance and repair.

As you disassemble the gun, lay out the components on a clean surface in the correct order and directions to assist you in reassembling them.

This manual also includes information about the following components:

- 58103-1                      High Volume Pro Gun Actuator Assembly
- 58106-1                      High Volume Pro Gun Block Assembly
- CPHV-1100                   High Volume Pro Gun Block Assembly
- 58110-1                      Repair Kit – High Volume Pro Gun
- CPHV-1000-RK              Repair Kit – High Volume Pro Gun

## Overview

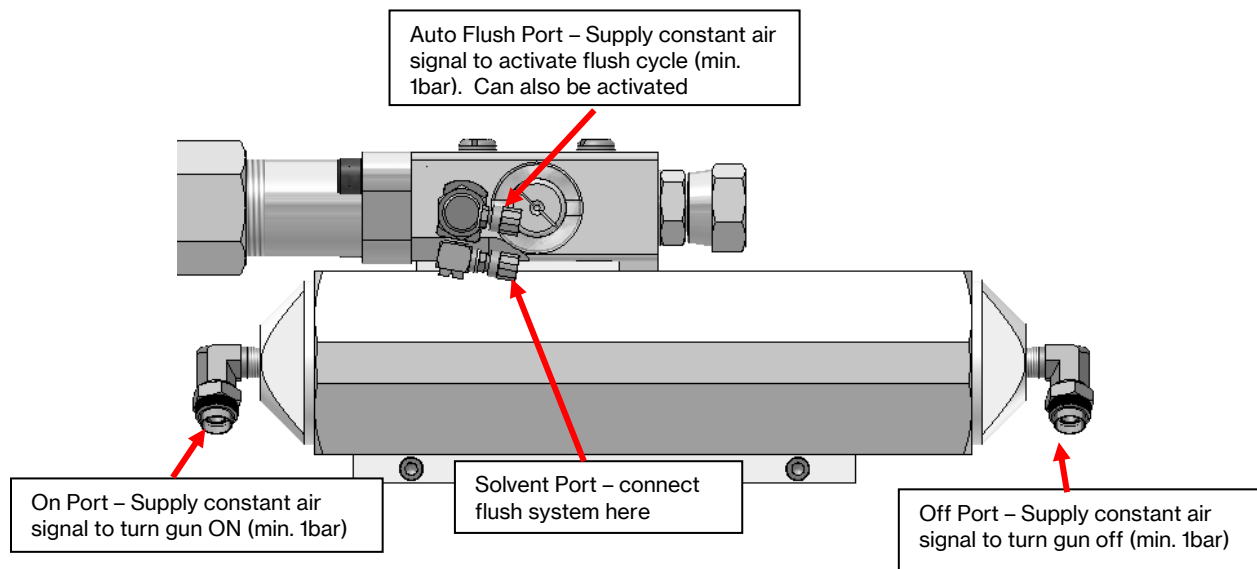

## Getting Started

### Materials Required

You will need the following items:

- Rubber mallet
- Thread sealant
- Adjustable wrench
- Needle-nose pliers
- Flat-head screwdriver
- Lubriplate™ lubricant
- Scribe set
- Pro Gun™ oil
- Seal installation tool
- HV Pro Gun™ packing bit
- Catalyst alignment tool
- Solvent for cleaning
- Clean shop towels or rags
- A small brush
- Empty containers in which to flush the gun
- Replacement O-rings and seals

**Note** *If you are using O-ring part number O-K-008 in the flush assembly, you do not need to replace the O-ring unless it is showing obvious signs of wear. This O-ring is designed to handle most solvents.*



**WARNING**

*To prevent accidental injection injury, disconnect all air and electrical power to the unit before beginning repair or maintenance on this equipment.*



**WARNING**

*To avoid injury, release all air pressure built up in the system before beginning repair or maintenance on this equipment.*

## Release Air Pressure

1. Turn off air supply to the pumping system.
2. Release fluid pressure from lines by holding the gun over an appropriate empty container and pulling the trigger.
3. Flush the gun into an appropriate container.
4. Turn off air supply to the solvent tank.
5. Release any pressure in the flush tank by gently pulling upward on the ring attached to the pressure relief valve.
6. Place an empty container under the ball valve located at the bottom of the system's filter assembly.
7. **Slowly** open the ball valve.

**Note** *You can leave the valve open or close it after all the pressure is released.*

8. Open the dump/recirculation valve on the catalyst manifold, if appropriate.

## Disable Catalyst Pump

9. If you have an Ultra Proportioning System (UPS), skip to step [14](#).

### Slave Arm Pumps

10. Remove the quick pin from the top of the catalyst pump and upper slave arm.
11. Tilt the catalyst pump away from the resin pump until it is resting against the vertical connecting post.
12. Trap the catalyst pump's upper bearing block between the vertical connecting post and the quick pin.
13. Skip to the steps to Remove Hoses.

## UPS

14. Remove the hairpin from the quick pin assembly.
15. Remove the quick pin assembly from the pivot link assembly.

## Remove Hoses



### **WARNING**

***There may still be trapped fluids under pressure in the lines. When removing hoses from fittings, follow the steps in this manual and remove the fitting slowly to allow any pressurized fluid to escape into the fabric.***



### **CAUTION**

***Wear appropriate eye protection. Pressurized fluids may cause eye injury.***

16. Wrap a large rag or shop towel around the resin fitting and a wrench.
17. Use the wrench to loosen the fitting slowly until you can remove the resin hose from the fitting.
18. Use the same technique to remove the solvent hose and the catalyst hose.

# **Disassembling the Gun**

## Disassemble into Modules

1. If your gun is not used for chopping, skip to step [4](#).
2. Detach the chopper assembly by removing the air tube that connects the chopper to its air supply.
3. Remove the hex cap screw securing the chopper to the top of the gun block, making sure not to lose the eccentric stud in the chopper mount.
4. Remove the four screws that secure the gun block to the actuator.
5. Set the gun block aside.

## Disassemble Actuator

### Remove Actuating Stem

6. Unscrew the actuating stem from the valve rod.
7. Tightly clamp the actuating stem into a soft-jawed vise and rotate the whole gun block.

### Remove and Disassemble Flush Valve Assembly

8. Unscrew the flush valve body from the gun block.
9. Remove the split seal from the flush valve body.

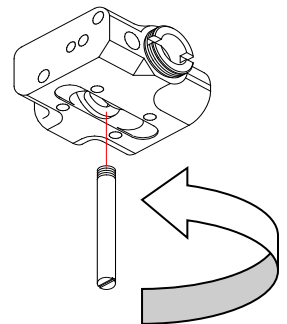

10. Remove the flush valve body from the flush valve neck.
11. Remove the flush valve seal from the flush valve body.

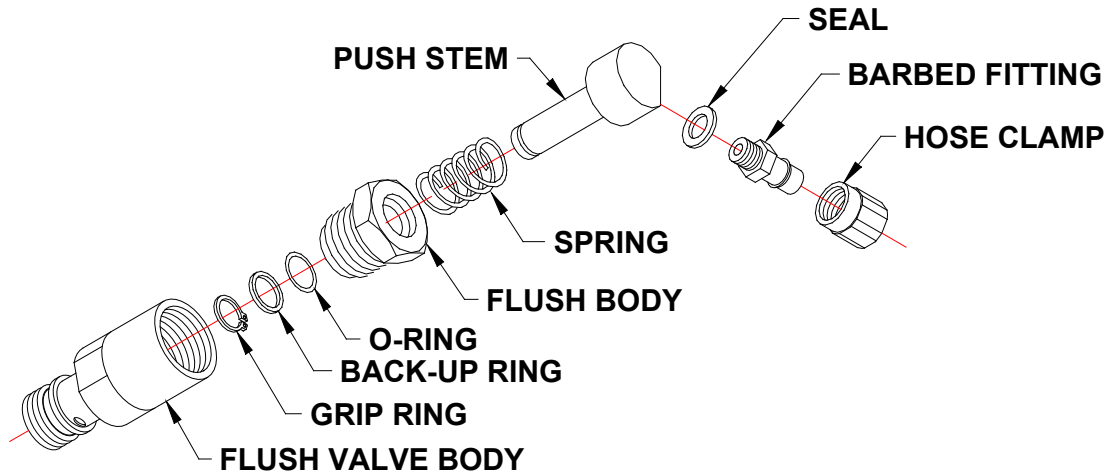

12. If your system does not have an auto/manual flush assembly, skip to step [16](#).
13. Unscrew the auto/manual flush body assembly from the flush valve body.
14. Remove the grip ring from the push stem of the auto/manual flush body assembly.

**Note** Use caution not to lose the spring in the flush body.

15. Remove the back-up ring and O-ring from the push stem.
16. Unscrew the flush seal body from the flush valve button.
17. Remove the spring.

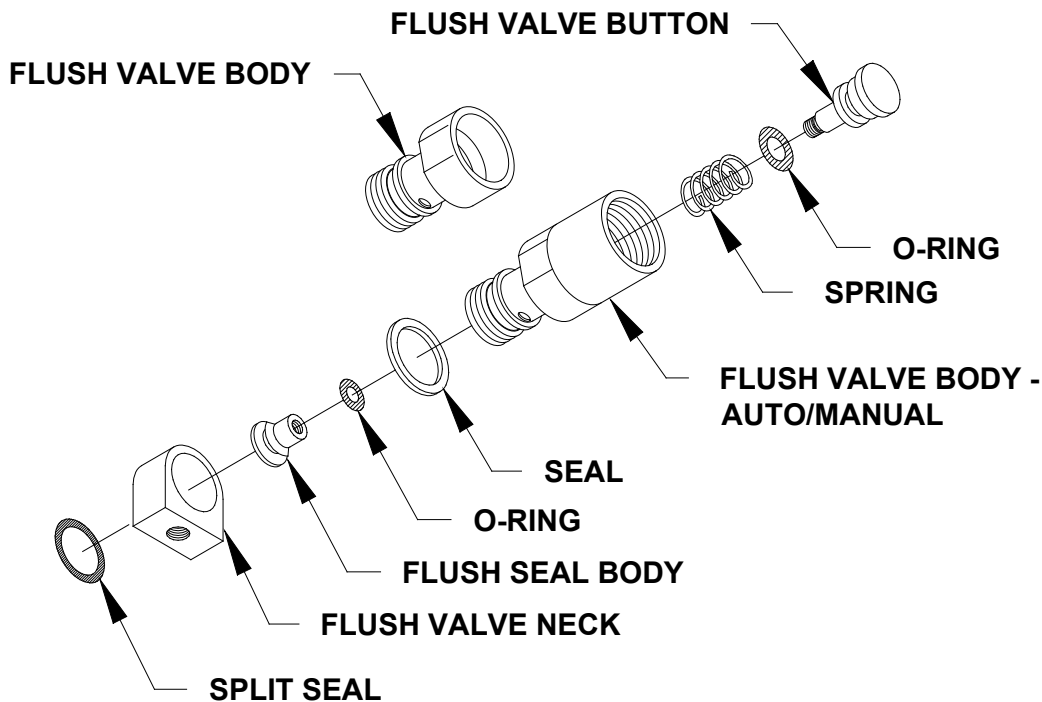

18. Use a scribe to remove the O-ring from the flush valve button.

19. Remove the O-ring from the flush seal body.
20. Discard and replace the flush valve's O-rings and seals.

**Note**     ***Do not replace O-ring O-K-008 unless it is worn or damaged. This O-ring is designed for use with all solvents. In some cases O-K-008 can be replaced with O-E-008.***

## Remove Mix Housing

21. Remove the nozzle cap from the mix housing.
22. Remove the nozzle from the cap.
23. Remove the mix housing by unscrewing the screws that hold the mix housing to the gun block.

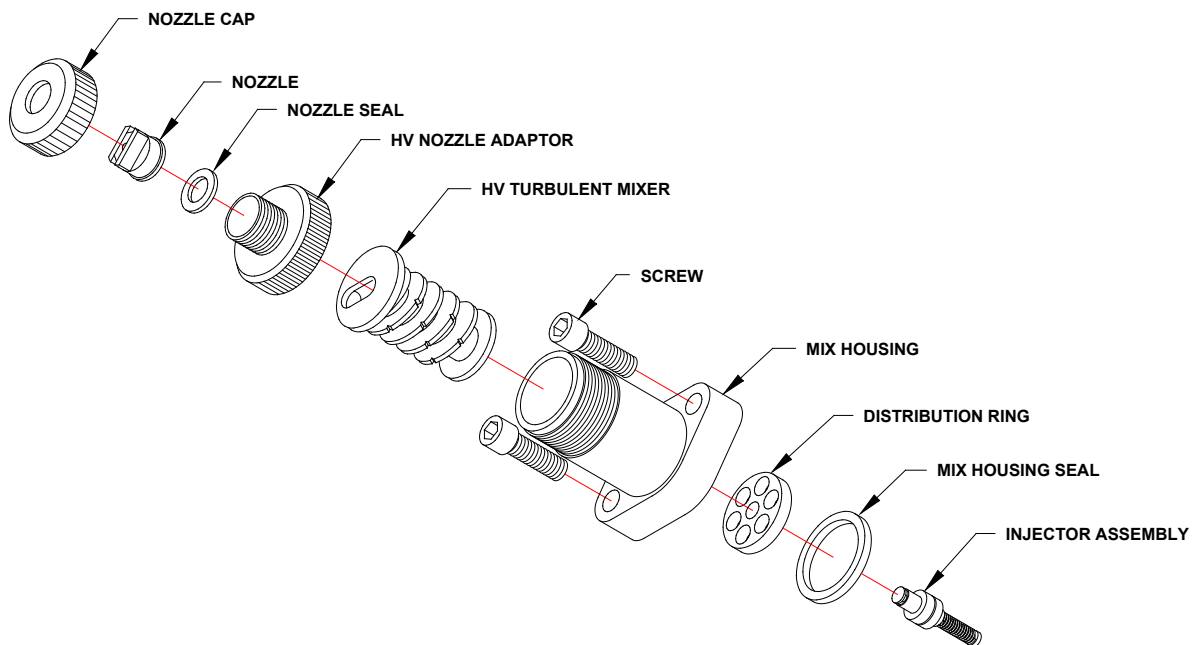

24. Pull the injector and injector seal out and set the injector assembly aside.
25. Remove the turbulent mixer or mixer plug from the mix housing.
26. Use a blunt tool to push the distribution ring and housing seal out of the mix housing.
27. Inspect and clean the mix housing components with solvent.

## Disassemble Catalyst Injector Assembly

28. Unscrew the plunger retainer from the end of the injector plunger.
29. Remove the spring.
30. Remove the injector plunger from the injector body.

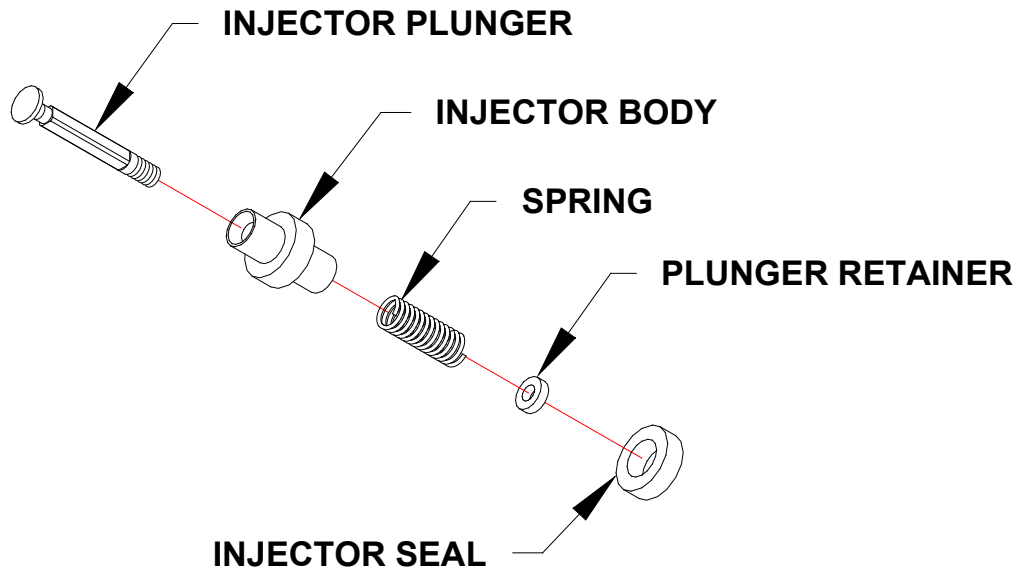

31. Inspect the injector plunger and body for dirt or damage.
32. Clean and reassemble.

## Disassemble Gun Block

### Remove Hose Fittings

33. Remove and clean the catalyst fitting and O-ring on the rear of the gun block.
34. Remove and clean the resin fitting and O-ring on the rear of the gun block.

### Remove Valve Rod

35. Use the packing bit to unscrew the packing nuts from both the catalyst and resin side.

**Note**      ***Use caution not to damage the packing bit. If you are unable to remove the packing nut, soak in solvent or apply heat to the packing nuts.***

36. Place the small end of the seal installation tool onto one end of the valve rod.
37. Use a **rubber** mallet or hammer to gently tap the valve rod out of the gun block.
38. Inspect the valve rod for damage and clean with solvent.

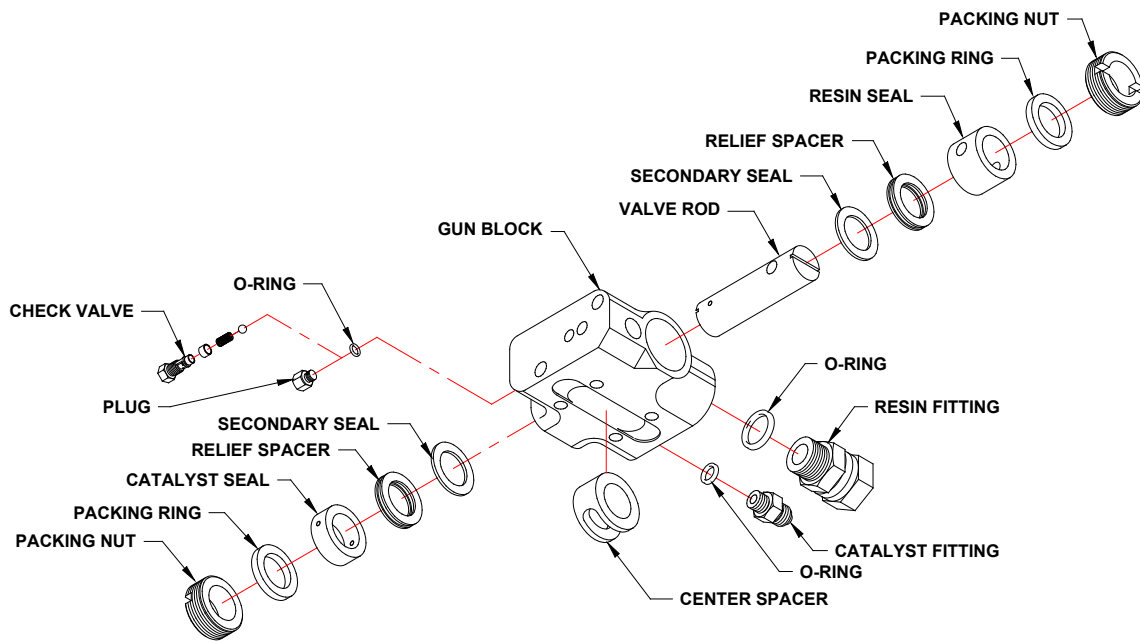

## Remove Spacer and Seals

39. Use needle-nose pliers to remove the center spacer.
40. Insert the seal installation tool into one of the side ports and gently tap it completely through the gun block with a rubber mallet or hammer.

As the tool is tapped through the interior of the gun block, it removes the seal sets for both the resin and catalyst sides.



### CAUTION

**Keep the components from the catalyst side separate from the components from the resin side. Mixing the components may result in cross-contamination.**

41. Clean the 2 relief spacers with solvent and allow to air dry.
42. Discard the seals and replace with new ones from the repair kit.

## Remove Check Valve or Catalyst Plug

43. Choose one of these options:
  - *If you have an international HV Pro Gun:* Remove the check valve on the side of the gun block.
  - *If you have a domestic HV Pro Gun:* Remove the plug from the side of the gun block and check the O-ring for damage.



### DANGER

**This serves as a check valve for the catalyst system. If this valve needs to be replaced, contact Magnum Venus Products. These valves have undergone remanufacture specific to use with the HV Pro Gun. Using a**

***check valve from another source may result in contaminations and/or dangerous ignition of the catalyst.***

## Clean Block Assembly

44. Discard used O-rings and seals.
45. Clean remaining components with solvent and allow to air dry.

# Reassembling Gun Block

## Install Seals and Spacer

1. Place one of the secondary seals into the center of the gun block where the center spacer goes.
2. Gently push the seal into position with something flat and flush with the gun block, using caution not to damage the seal.
3. Repeat both steps for the other secondary seal.

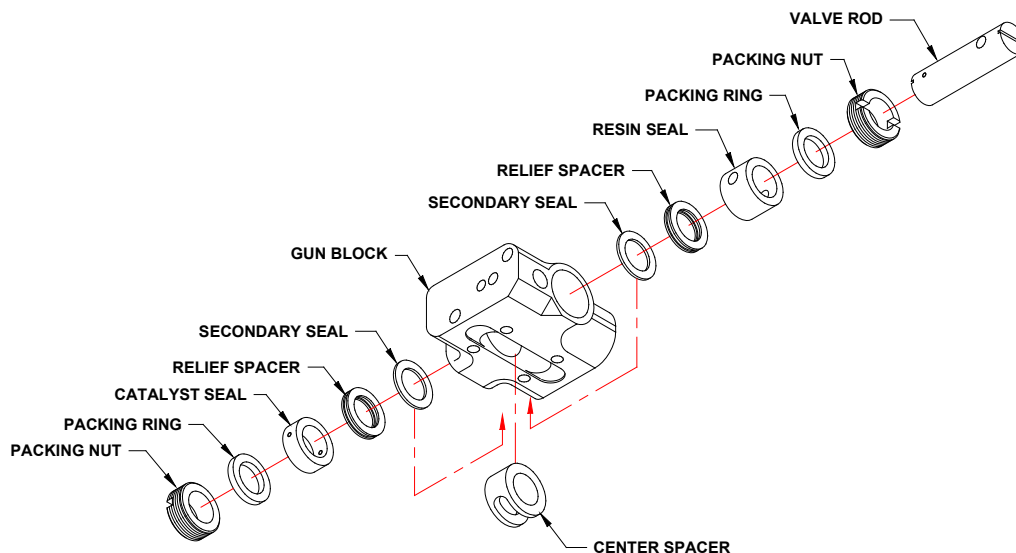

4. Place the center spacer back into the gun block, making sure that the spacer is aligned as accurately as possible with the slot facing up.

**Note**      ***Use caution not to damage the newly installed secondary seals.***

## Reassemble Catalyst Components

5. Place the catalyst components onto the seal installation tool in the following order:
  - Packing Ring
  - Catalyst Seal
  - Relief Spacer

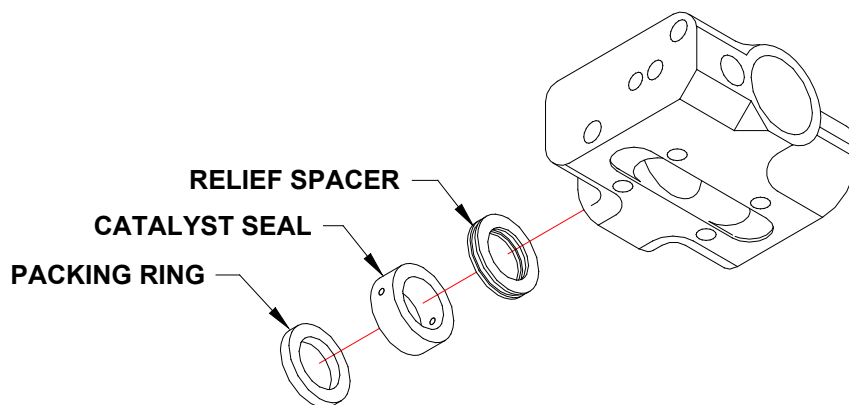

6. Insert the seal installation tool with the components on it into the catalyst side of the gun block.

**Note**      ***Align the hole in the catalyst seal with the port in the gun block before inserting the seal installation tool into the gun block.***

7. Press firmly, or tap with a rubber mallet, then pull the packing tool out of the gun block.
8. Check to make sure the catalyst components are seated in the interior of the gun block against the center spacer.
9. Gently screw a packing nut into the catalyst side, but do not tighten.

### **Align Catalyst Seal**

10. Hold the catalyst alignment tool (tapered drill bit) firmly with a pair of pliers.
11. Insert the alignment tool, tapered end first, into the gun block through the catalyst side on the rear.
12. Gently press and move the alignment tool around until the holes in the catalyst seal align with the port in the gun block.

**Note**      ***At this point, the catalyst side packing nut should only be hand tight.***

### **Reassemble Resin Components**

13. Place the resin components onto the seal installation tool in the following order:
  - Packing Ring
  - Resin Seal
  - Relief Spacer
14. Insert the seal installation tool into the resin side of the gun block.

**Note**      ***Before inserting the packing tool, align the hole in the resin seal with the hole in the gun block as closely as possible.***

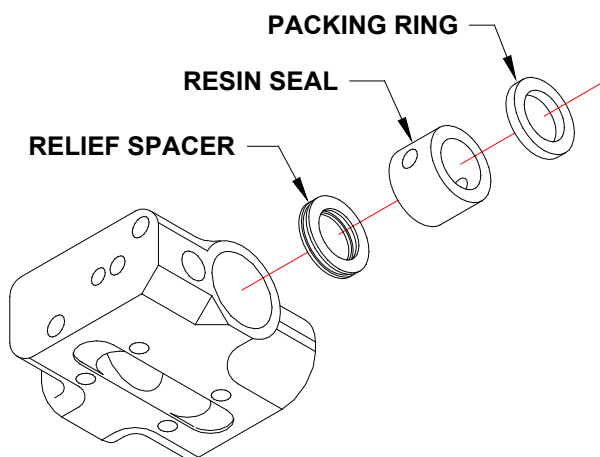

15. Tap gently with a rubber mallet or hammer, and then pull the packing tool out of the gun block.
16. Check to make sure the resin components are seated in the interior of the gun block against the center spacer.
17. Gently screw a packing nut into the resin side, but do not tighten.

## Install Valve Rod and Actuating Stem

18. Use a packing tool center the valve rod, then insert the valve rod into the gun block through the resin side.

**Note** *Make sure the valve rod is correctly aligned; the larger hole goes on the resin side while the smaller hole goes on the catalyst side.*

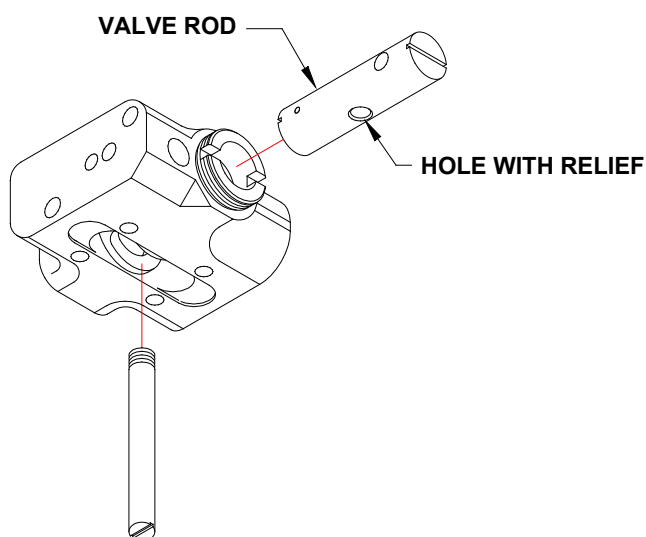

**Note** *Make sure the middle hole with the relief is facing out of the gun block.*

19. Screw the actuating stem into the valve rod through the center spacer.

20. Make sure the stem is screwed into the side of the valve role with the larger hole with thread relief.
21. Look down the front of the gun while moving the actuating stem back and forth to observe the holes opening and closing.
22. Set the actuating stem so that the holes are closed.

## Tighten Packing Nuts

23. Tighten both the resin and catalyst packing nuts, making sure not to damage the packing bit.
24. Move the actuating stem back and forth, opening and closing the gun.
25. Retighten both the resin and catalyst packing nuts.
26. Repeat steps [23](#) - [25](#).

## Reinstall Fittings and Valves

27. Reinstall the fitting and O-ring for the resin hose on the rear of the gun block.
28. Reinstall the catalyst fitting and O-ring on the rear of the gun block.
29. Choose one of these options:
  - *If you have an international HV Pro Gun:* Reinstall the check valve and O-ring on the front side port on the catalyst side of the gun block.
  - *If you have a domestic HV Pro Gun:* Thread the catalyst plug into the front side port on the catalyst side of the gun block.

## Reassemble Flush Valve

30. Place the O-ring on the flush valve button.
31. Insert the spring onto the flush valve button.
32. Push the button and spring into the flush valve body.

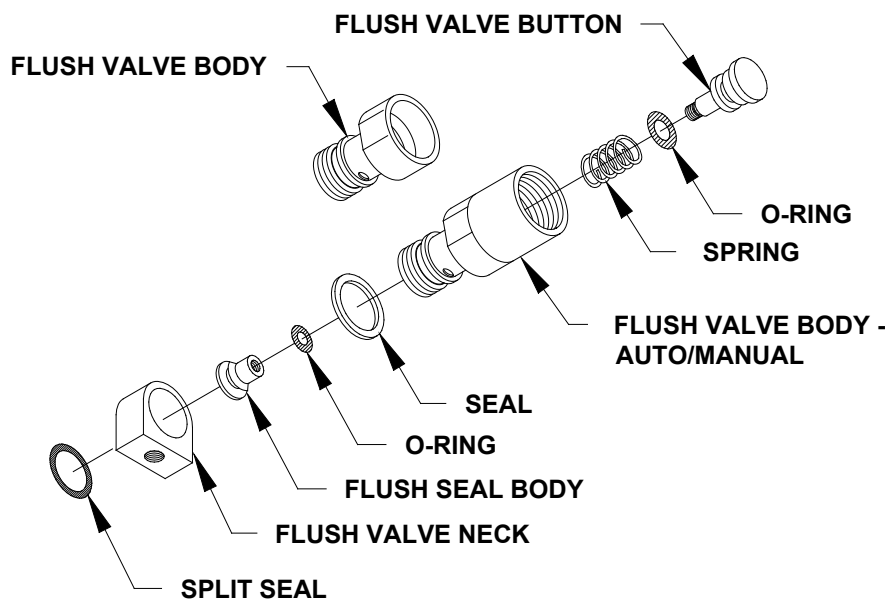

33. Place the O-ring on the flush seal body.
34. Insert the flush seal body into the end of the flush valve body and screw it onto the button.
35. Place a flush valve seal on the flush valve body.
36. Install the flush valve body into the flush valve neck.
37. Install the split seal onto the flush valve body.
38. If your system does not have an auto/manual flush assembly, skip to step
39. Install the spring and push stem into the flush body.
40. Install a new O-ring onto the end of the push stem sticking out of the flush body.

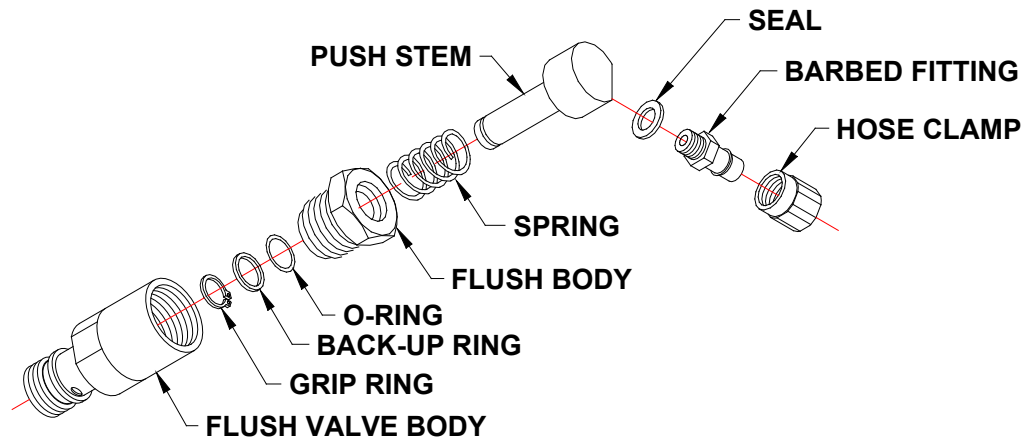

41. Install the back-up ring onto the end of the push stem against the new O-ring.
42. Install the grip ring onto the end of the push stem.
43. Thread the auto/manual flush body assembly into the flush valve body.
44. Screw the flush valve assembly into the front side port on the resin side of the gun block.

## Reassemble Mix Housing

45. Install the distribution ring into the mix housing.

**Note**      ***Be sure the holes in the distribution ring are clean and free of debris or hardened material.***

46. Position the mix housing seal into the mix housing, against the distribution ring.
47. Insert the catalyst injector assembly and injector seal into the center hole of the distribution ring.

**Note**      ***The spring should be facing up, as it will go into the gun block and the injector seal will be against the gun block.***

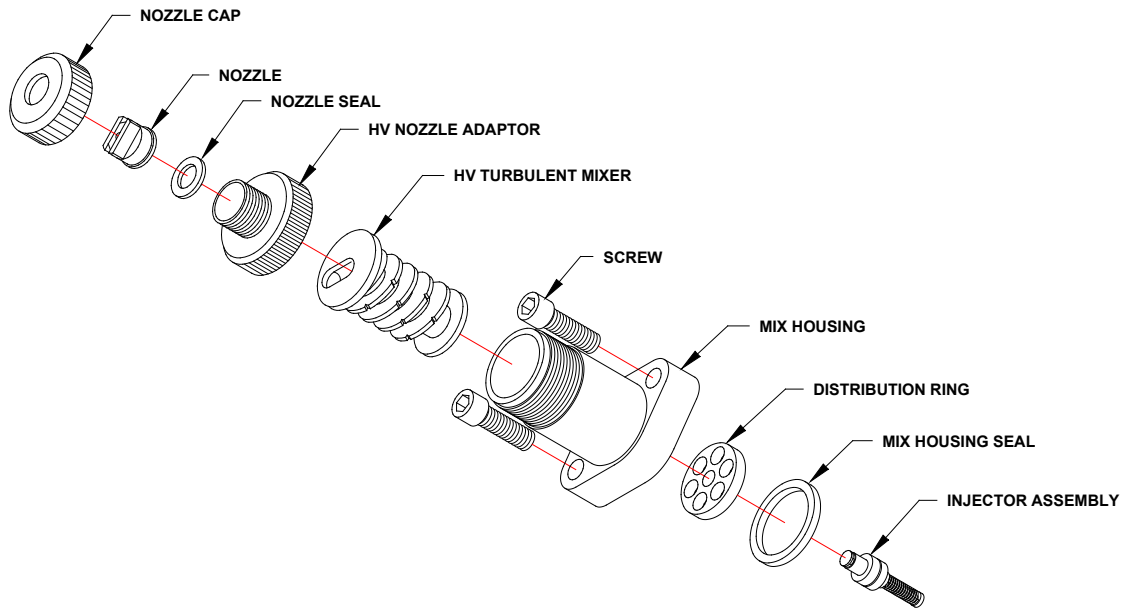

48. Use the socket cap screws to attach the mix housing to the gun block.



**WARNING**

***Screws and fasteners provided with the gun are specially designed for this equipment. Use only Magnum Venus Products replacement parts, or warranty may be voided.***

- 49. Insert the turbulent mixer or mixer plug into the mix housing.
- 50. Apply some red grease to the threads of the mix housing and nozzle cap to facilitate removal later.
- 51. Install HV nozzle adaptor to the mix chamber.
- 52. Install the nozzle into the nozzle cap.
- 53. Screw the nozzle and nozzle cap onto the mix housing.

**Note**      ***The mix housing assembly may differ from the standard mix housing pictured depending on the way your system is used.***

## **Rebuilding the Actuator**

1. Remove the end cap from both ends of the cylinder body.
2. Push the actuator piston out the back of the cylinder body.
3. Replace the O-ring on the actuator piston.
4. Check the actuator bushing and cylinder body for wear or damage.
5. Apply a light coating of Pro Gun Oil to both the inside of the cylinder and the actuator piston.
6. Install the actuator piston into the cylinder body, with the actuator bushing going in first and off center toward the top.

7. Install the end cap onto both ends of the cylinder body.

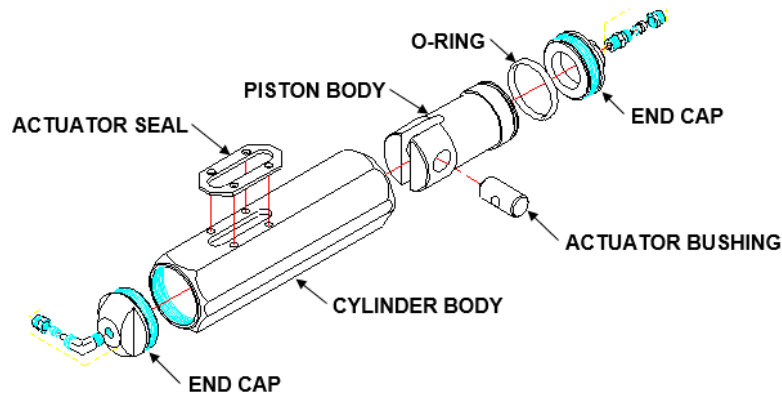

## Assembling Components

1. Install the actuator seal on top of the actuator cylinder.
2. Align the actuator stem on the gun block with the actuator bushing in the cylinder body.
3. Attach the gun block to the cylinder using the four screws and seals.
4. Attach the chopper mount and chopper to the front of the gun block.
5. Install the mounting pad to the bottom of the cylinder body using the screws.

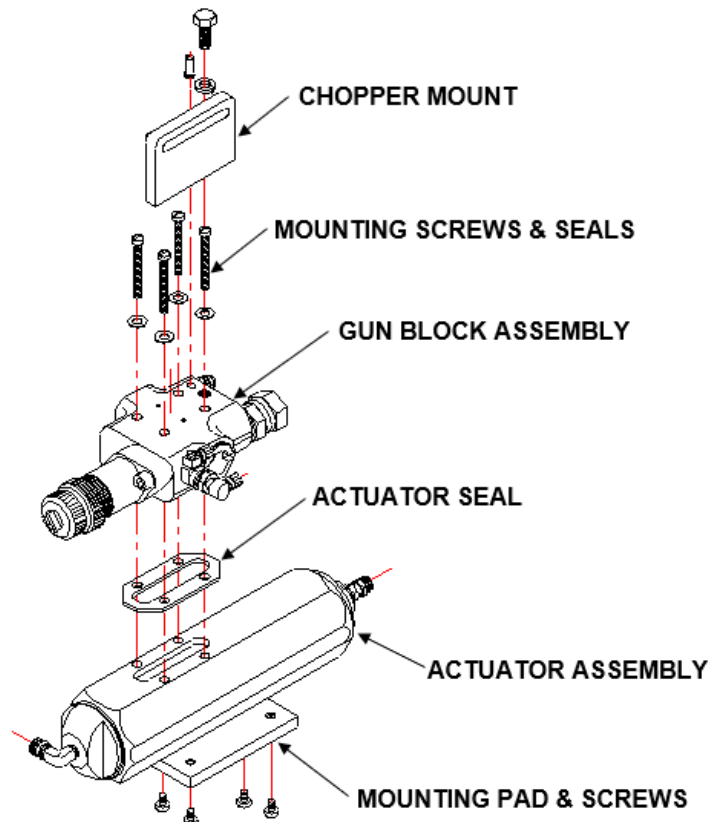

# Specifications

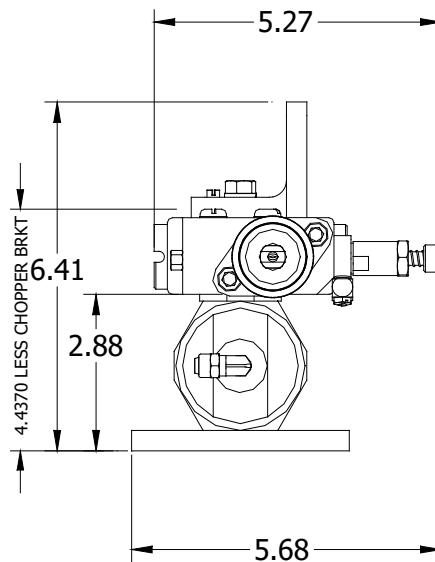
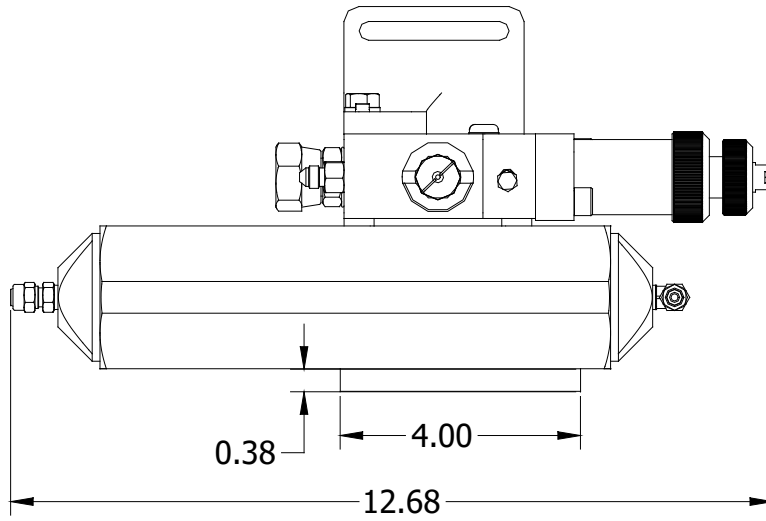
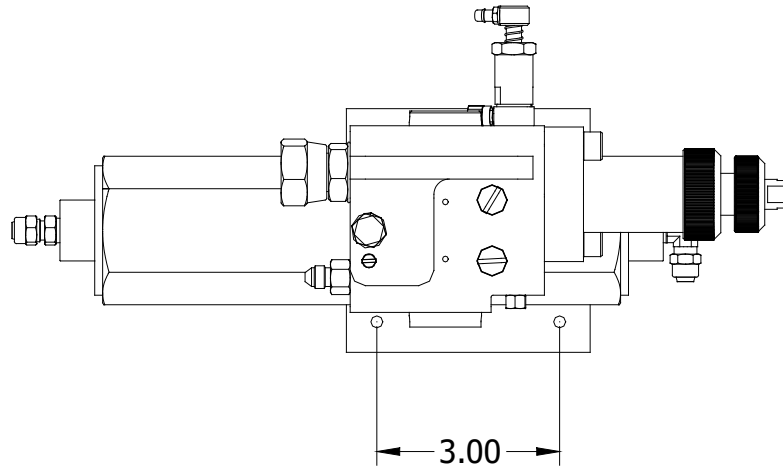

HV PRO GUN THREADS

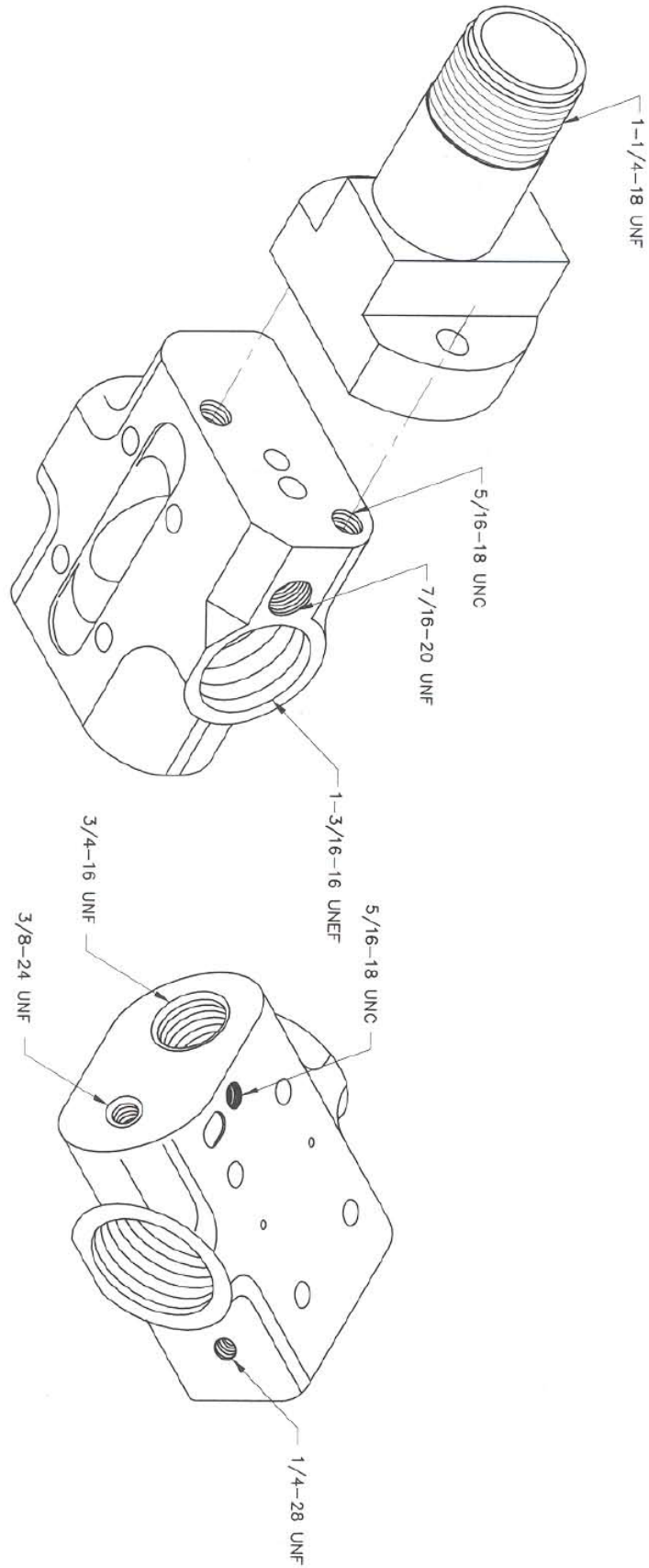



# Parts Drawings

<b>Applicable Parts</b>	
<b>Part Number</b>	<b>Description</b>
58100-1-X	High Volume Pro Gun Assembly – Saturator
58104-1	High Volume Pro Gun Assembly – Manual Operated
58105-1	High Volume Pro Gun Assembly – For Chopper
606025-1	High Volume Pro Gun Assembly – Manual Putty
60625-1-INT	High Volume Pro Gun Assembly – Manual Putty International
CPHV-1000	High Volume Pro Gun Assembly – Pneumatic Operator
CPHV-1000-EP	High Volume Pro Gun Assembly – Electric Operator
58103-1	High Volume Pro Gun Actuator Assembly
HVDG-4200	Dual HV Gun Actuator
HVDG-4200-EP	Dual HV Gun Actuator – Electrical
58106-1-X	High Volume Pro Gun Block Assembly
CPHV-1100	High Volume Pro Gun Block Assembly
58742-1	Automatic Flush Valve Assembly
58742-1-INT	Automatic Flush Valve Assembly – International
58715-1	Auto/Manual Flush Valve Assembly
58115-1	Catalyst Injector Assembly
PRO-HV-TT	Ratio Test Tip
58110-1	Repair Kit – High Volume Pro Gun
58110-1-INT	Repair Kit – High Volume Pro Gun – International
CPHV-1000-RK	Repair Kit – High Volume Pro Gun
HVPRO-2000-A	High Volume Automatic Pro Gun
CPHV-2000	High Volume Pro Gun

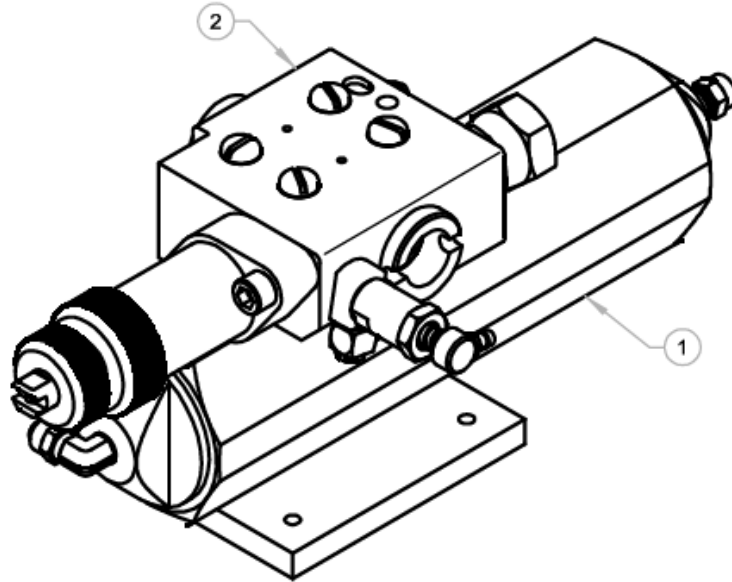

## MAGNUM VENUS PRODUCTS

HV Auto Pro Gun Assembly

58100-1

Int. HV Auto Pro Gun Assembly

58100-1-INT

REV. -- 10/4/06 jem

**HV Auto Pro Gun Assembly    58100-1**

**PARTS LIST**

ITEM	PART NO.	QTY	DESCRIPTION
1	58103-1	1	ACTUATOR ASSY - HV PRO
2	58106-1	1	HV PRO GUN ASSY

**Int. HV Auto Pro Gun Assembly    58100-1-INT**

**PARTS LIST**

ITEM	PART NO.	QTY	DESCRIPTION
1	58103-1	1	ACTUATOR ASSY - HV PRO
2	58106-1-INT	1	HV PRO GUN ASSY



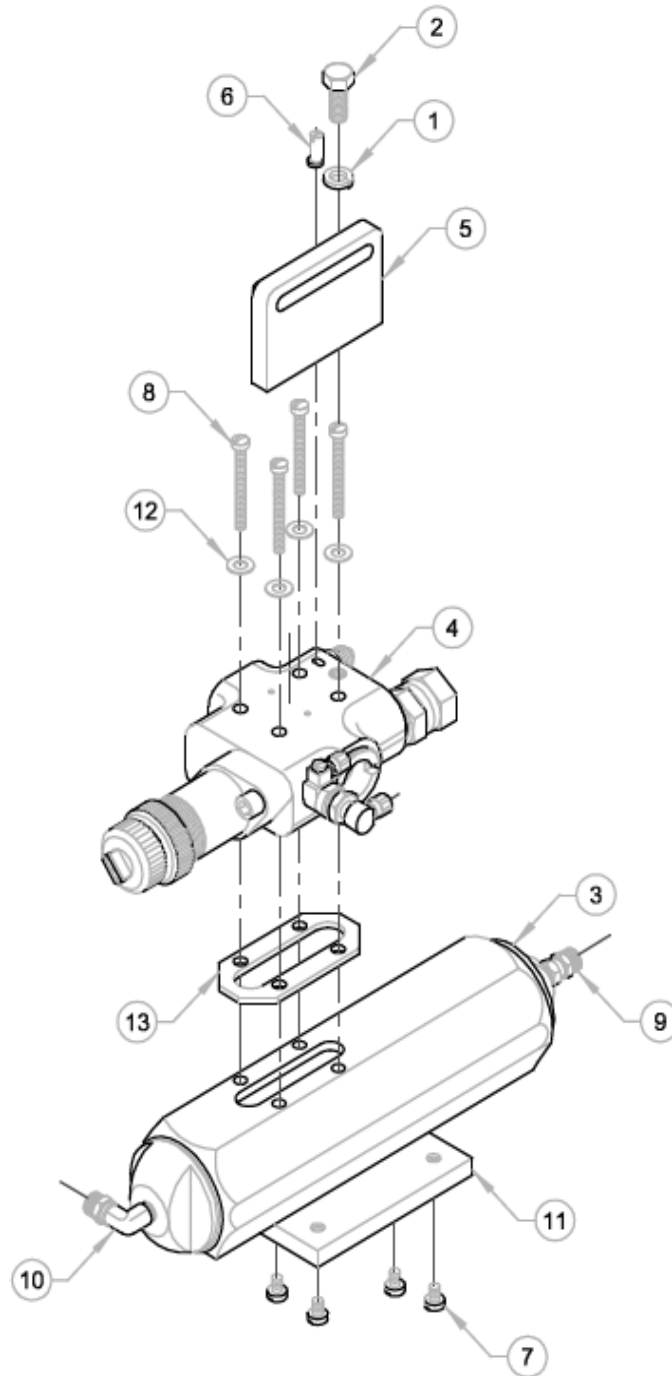

## MAGNUM VENUS PLASTECH

HV AUTO CHOP GUN ASSEMBLY

58105-1

REV: - 4/25/02 JEM  
REV: A - UPDATED PART NUMBERS TO ALPHA-NUMERIC 08/31/13 BT2  
REV: B - ADDED REPAIR KIT 06/17/16 BT2

**HV AUTO CHOP GUN ASSY 58105-1****PARTS LIST**

ITEM	PART NO.	QTY	DESCRIPTION
1	F-SW-05	1	LOCK WASHER
2	F-HB-05C-12	1	HEX BOLT
3	58103-1	1	HV PRO GUN ACTUATOR ASSY
4	58106-1	1	HV PRO GUN BLOCK ASSY
5	58142-1	1	CHOPPER MOUNTING BRACKET
6	5103-17-1	1	ECCENTRIC STUD

**ASSOCIATED PARTS COME WITH 58103-1 ASSY**

ITEM	PART NO.	QTY	DESCRIPTION
7	02809-3	4	PAN HEAD MACHINESCREW
8	F-PH-04C-28	4	PAN HEAD MACHINE SCREW
9	7701-6-14	1	CONNECTOR
10	MPH-2534	1	ELBOW CONNECTOR
11	58141-1	1	MOUNTING PLATE
12	58143-1	4	SEAL
13	58144-1	1	ACTUATOR SEAL

**REPAIR KIT**

PART NO.	DESCRIPTION
58110-1	HV PRO GUN REPAIR KIT

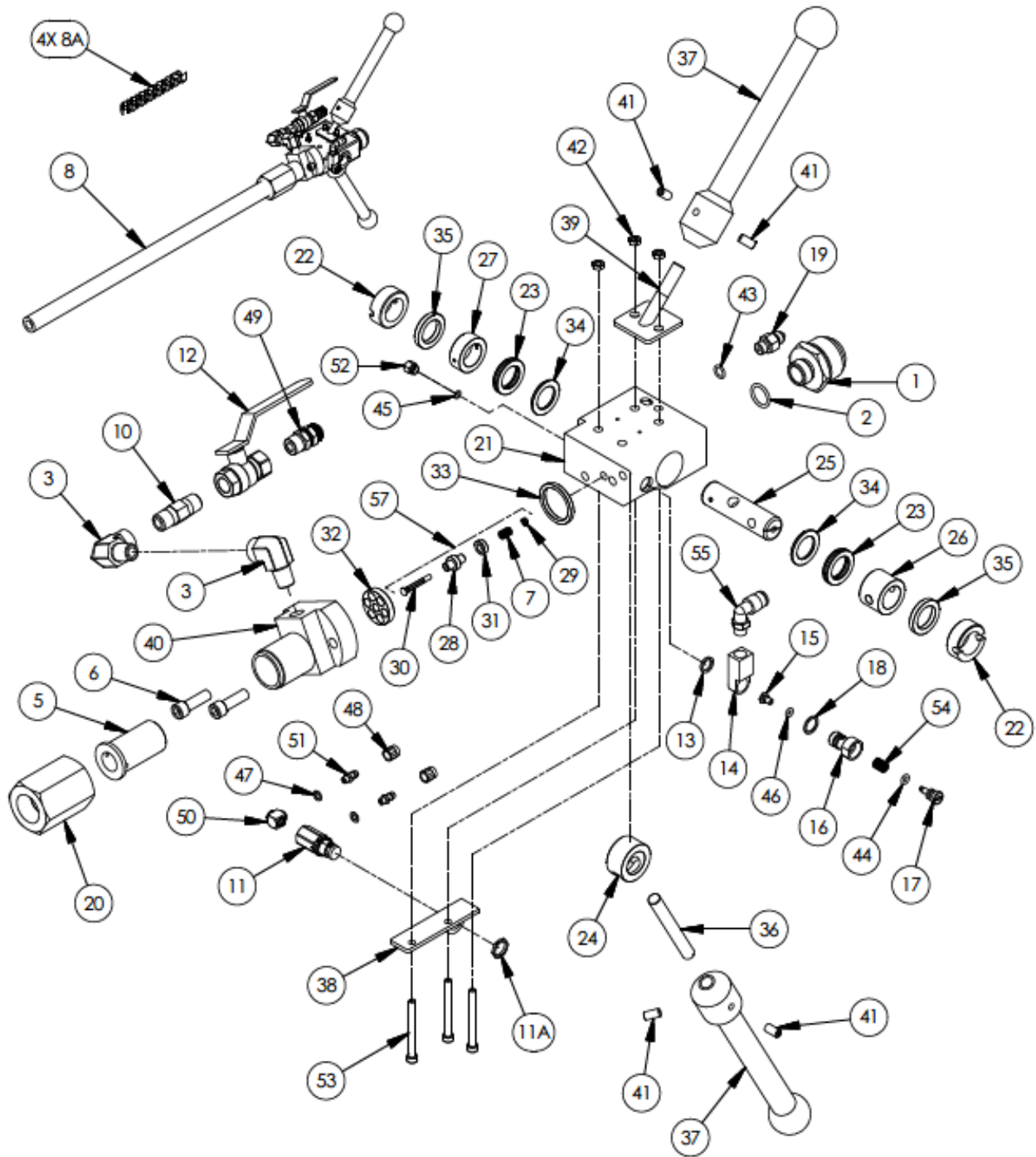

# MAGNUM VENUS PRODUCTS

MANUAL GUN BLOCK - HV PUTTY

60625-1

REV: S 08/18/2016

SHEET 1 / 2

8/18/2016

Parts List				
ITEM	PART NUMBER	QTY	DESCRIPTION	
	1	02216	1	HEX NIPPLE
*	2	O-V-3-908	1	O-RING
	3	PF-SE-04-SS	2	STREET ELBOW
	5	55011-1	1	MIXER PLUG
	6	F-CS-05F-16-GRB	2	CAP SCREW
	7	04354	1	INJECTOR SPRING
	8	05260	1	MIXER TUBE
	10	07879	1	CHECK VALVE
	11	09169	1	3-WAY VALVE
	12	BV-FF44-L	1	BALL VALVE
*	13	5104-21-1	1	FLUSH VALVE SPLIT SEAL
	14	5104-22-2	1	FLUSH VALVE NECK
	15	5104-23-1	1	FLUSH SEAL BODY
	16	5104-24-1	1	FLUSH VALVE BODY
	17	5104-25-1	1	FLUSH VALVE BUTTON
*	18	5104-26-1	1	FLUSH VALVE SEAL
	19	7701-3-6	1	CONNECTOR FITTING
	20	54861-1	1	UNION
	21	58121-1	1	HIGH VOLUME GUN BLOCK
	22	58122-1	2	PACKING NUT
	23	58123-1	2	RELIEF SPACER
	24	58124-1	1	CENTER SPACER
	25	58125-1	1	VALVE ROD
*	26	58126-1	1	RESIN SEAL
*	27	58127-1	1	CATALYST SEAL
	28	58128-1	1	INJECTOR BODY
	29	58129-1	1	PLUNGER RETAINER
	30	58130-1	1	INJECTOR PLUNGER
*	31	58131-1	1	INJECTOR SEAL
	32	58133-1	1	DISTRIBUTION RING
*	33	58134-1	1	SEAL MIX HOUSING
*	34	58135-1	2	SECONDARY SEAL
*	35	58146-1	2	PACKING RING
	36	58147-1	1	STEM
	37	58148-1	2	HANDLE
	38	58149-1	1	MOUNT BRACKET - 3-WAY VALVE
	39	58151-1	1	WELDMENT - HANDLE SUPPORT
	40	60570-1	1	AIR PURGE- MIX HOUSING
	41	F-SS-04C-08	4	SET SCREW
	42	F-HN-1032	3	HEX NUT
*	43	O-S-3-903	1	O-RING
*	44	O-E-008	1	O-RING
*	45	O-S-5-125	1	O-RING
*	46	O-E-007	1	O-RING
*	47	7304-3-1	2	NYLON SEAL
	48	7701-2-1	2	HOSE CLAMP - POLY TUBE
	49	7701-3-35	1	MALE CONNECTOR
	50	TRU-1021	1	SWIVEL ELBOW FITTING
	51	7701-6-3	2	BARBED FITTING
	52	5104-32-1	1	PLUG
	53	F-CS-1032-32	3	CAP SCREW
	54	9203-2-3	1	COMPRESSION SPRING
	55	MPH-2539	1	MALE ELBOW

\* REPAIR KIT:  
58110-1 HV PRO GUN REPAIR KIT (KIT WILL CONTAIN SOME ITEMS NOT USED IN 60625-1)

AVAILABLE SEPARATELY:

8A MPD-9750-03 MIXER ELEMENT (QTY. 4)  
11A MPM-2587 NUT  
44B O-K-008 O-RING  
57 58115-1 INJECTOR ASSEMBLY

AVAILABLE TOOLS:

58198-1 SEAL INSTALLATION TOOL  
58199-1 PACKING TOOL

## MAGNUM VENUS PRODUCTS

MANUAL GUN BLOCK - HV PUTTY	60625-1
-----------------------------	---------

REV: 5 08/18/2016

SHEET 2 / 2

8/18/2016



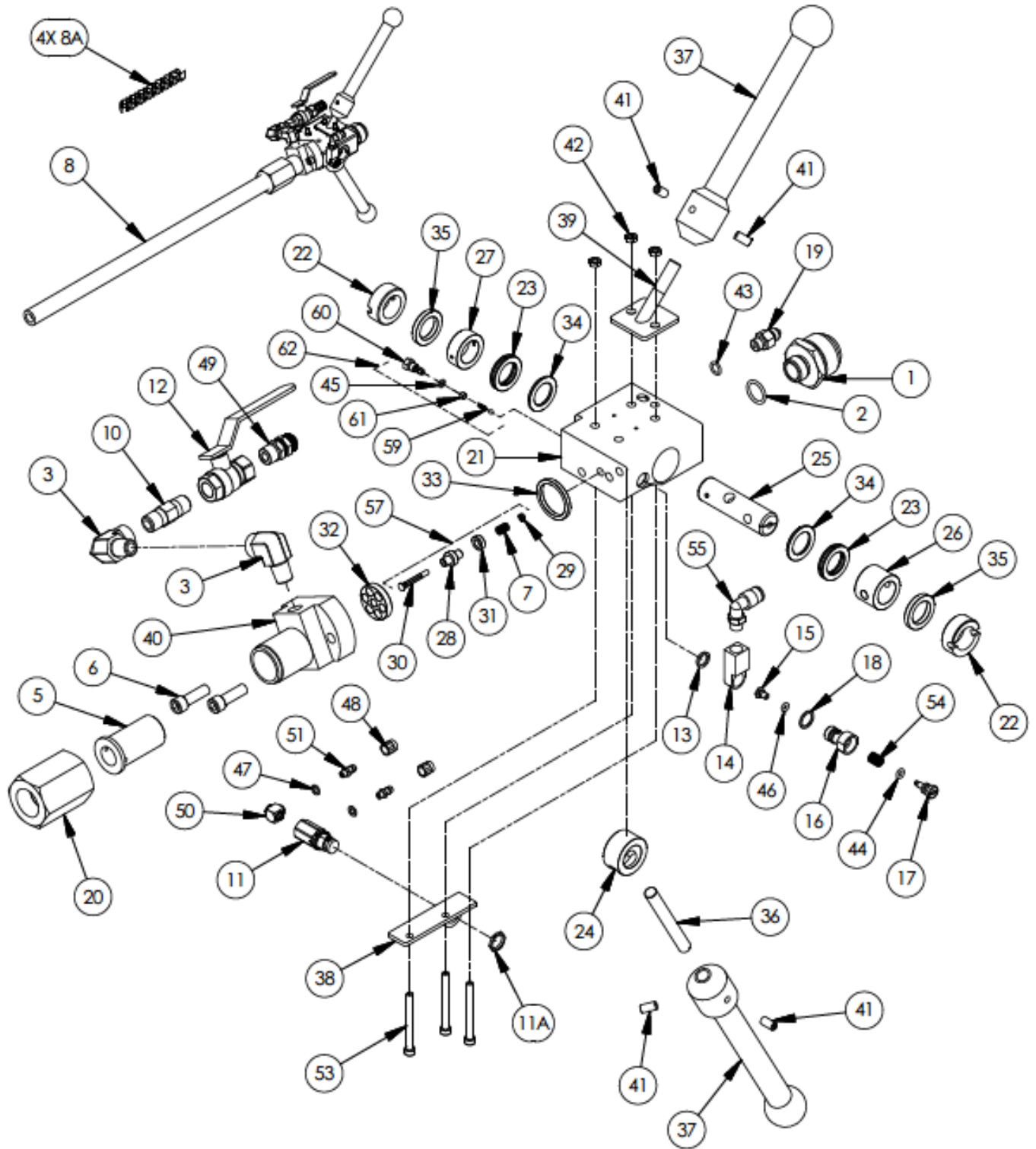

# MAGNUM VENUS PRODUCTS

MANUAL GUN BLOCK - HV PUTTY 60625-1-INT

REV: F 08/18/2016

SHEET 1 / 2

8/18/2016



Parts List			
ITEM	PART NUMBER	QTY	DESCRIPTION
	1	02216	1 HEX NIPPLE
*	2	O-V-3-908	1 O-RING
	3	PF-SE-04-SS	2 STREET ELBOW
	5	55011-1	1 MIXER PLUG
	6	F-CS-05F-16-GR8	2 CAP SCREW
	7	04354	1 INJECTOR SPRING
	8	05260	1 MIXER TUBE
	10	07879	1 CHECK VALVE
	11	09169	1 3-WAY VALVE
	12	BV-FF44-L	1 BALL VALVE
*	13	5104-21-1	1 FLUSH VALVE SPLIT SEAL
	14	5104-22-2	1 FLUSH VALVE NECK
	15	5104-23-1	1 FLUSH SEAL BODY
	16	5104-24-1	1 FLUSH VALVE BODY
	17	5104-25-1	1 FLUSH VALVE BUTTON
*	18	5104-26-1	1 FLUSH VALVE SEAL
	19	7701-3-6	1 CONNECTOR FITTING
	20	54861-1	1 UNION
	21	58121-1	1 HIGH VOLUME GUN BLOCK
	22	58122-1	2 PACKING NUT
	23	58123-1	2 RELIEF SPACER
	24	58124-1	1 CENTER SPACER
	25	58125-1	1 VALVE ROD
*	26	58126-1	1 RESIN SEAL
*	27	58127-1	1 CATALYST SEAL
	28	58128-1	1 INJECTOR BODY
	29	58129-1	1 PLUNGER RETAINER
	30	58130-1	1 INJECTOR PLUNGER
*	31	58131-1	1 INJECTOR SEAL
	32	58133-1	1 DISTRIBUTION RING
*	33	58134-1	1 SEAL MIX HOUSING
*	34	58135-1	2 SECONDARY SEAL
*	35	58146-1	2 PACKING RING
	36	58147-1	1 STEM
	37	58148-1	2 HANDLE
	38	58149-1	1 MOUNT BRACKET - 3-WAY VALVE
	39	58151-1	1 WELDMENT - HANDLE SUPPORT
	40	60570-1	1 AIR PURGE- MIX HOUSING
	41	F-SS-04C-08	4 SET SCREW
	42	F-HN-1032	3 HEX NUT
*	43	O-S-3-903	1 O-RING
*	44	O-E-008	1 O-RING
*	45	O-S-5-125	1 O-RING
*	46	O-A-007	1 O-RING
*	47	7304-3-1	2 NYLON SEAL
	48	7701-2-1	2 HOSE CLAMP - POLY TUBE
	49	7701-3-35	1 MALE CONNECTOR
	50	TRU-1021	1 SWIVEL ELBOW FITTING
	51	7701-6-3	2 BARBED FITTING
	53	F-CS-1032-32	3 CAP SCREW
	54	9203-2-3	1 COMPRESSION SPRING
	55	MPH-2539	1 MALE ELBOW
	59	7702-1-6	1 BALL AND SPRING
	60	7702-1-4	1 CHECK VALVE BODY
	61	7702-1-5	1 CHECK VALVE SLEEVE

\* REPAIR KIT:  
58110-1-INT HV PRO GUN REPAIR KIT (KIT WILL CONTAIN SOME ITEMS NOT USED IN 60625-1)

AVAILABLE SEPARATELY:

8A MPD-9750-03 MIXER ELEMENT (QTY. 4)  
11A MPM-2587 NUT  
44B O-K-008 O-RING  
57 58115-1 INJECTOR ASSEMBLY  
62 5104-04-01 CHECK VALVE ASSEMBLY

AVAILABLE TOOLS:

58198-1 SEAL INSTALLATION TOOL  
58199-1 PACKING TOOL

# MAGNUM VENUS PRODUCTS

MANUAL GUN BLOCK - HV PUTTY	60625-1-INT
-----------------------------	-------------

REV: F 08/18/2016

SHEET 2 / 2

8/18/2016



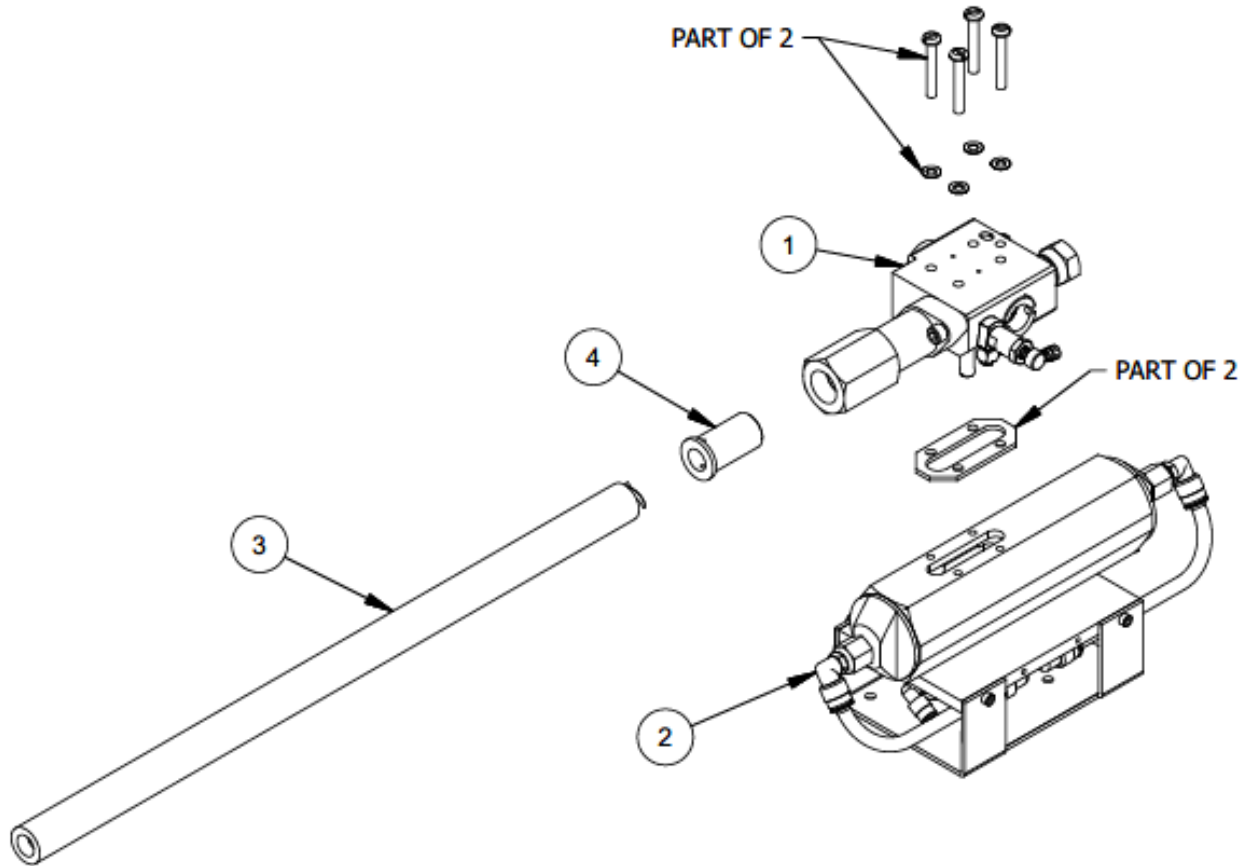

# MAGNUM VENUS PRODUCTS

HIGH VOLUME PRO GUN WITH PNEUMATIC OPERATOR VALVE

CPHV-1000

REV: A 10/04/2017

SHEET 1 / 2

4/12/2016

Parts List			
ITEM	PART NUMBER	QTY	DESCRIPTION
1	CPHV-1100	1	HIGH VOLUME PRO GUN BLOCK ASSEMBLY
2	HVDG-4200	1	DUAL HIGH VOLUME DUO GUN ACTUATOR
3	05260	1	MIXER TUBE
4	55011-1	1	MIXER PLUG

REPAIR KIT - CPHV-1000-RK (INCLUDES ITEMS IN CPHV-1100 AND HVDG-4200)

OPTIONAL ITEM

MPD-9750-03 MIXER ELEMENT FOR 05260 (4 PER ASSEMBLY)

# MAGNUM VENUS PRODUCTS

HIGH VOLUME PRO GUN WITH PNEUMATIC OPERATOR VALVE

CPHV-1000

REV: A 10/04/2017

SHEET 2 / 2

4/12/2016



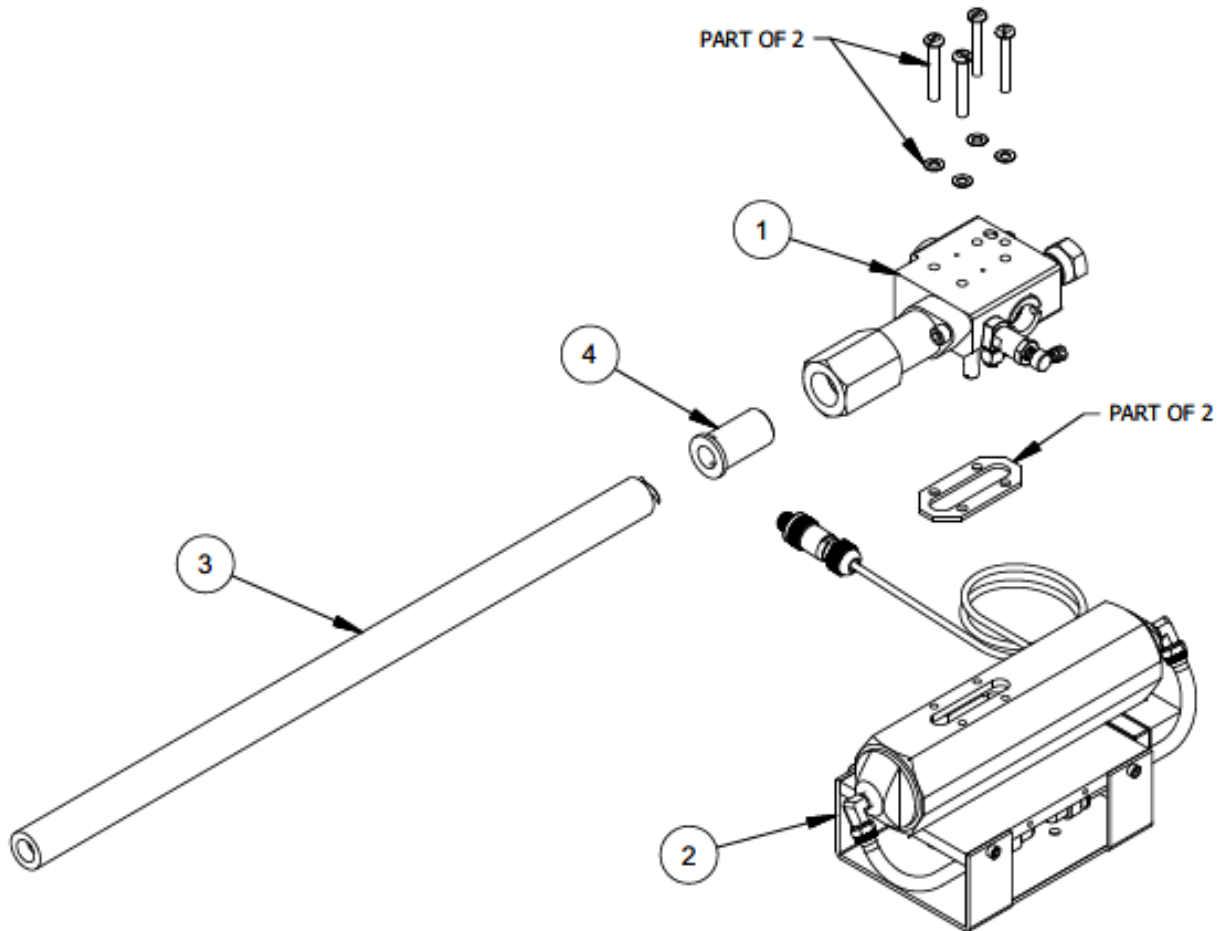

# MAGNUM VENUS PRODUCTS

HIGH VOLUME PRO GUN WITH ELECTRIC OPERATOR VALVE	CPHV-1000-EP
--	--------------

REV:

SHEET 1 / 2

4/12/2016

Parts List			
ITEM	PART NUMBER	QTY	DESCRIPTION
1	CPHV-1100	1	HIGH VOLUME PRO GUN BLOCK ASSEMBLY
2	HVDG-4200-EP	1	GUN ACTUATOR WITH ELECTRIC OPERATOR VALVE
3	05260	1	MIXER TUBE
4	55011	1	MIXER PLUG

REPAIR KIT - CPHV-1000-RK (INCLUDES ITEMS IN CPHV-1100 AND HVDG-4200-EP)

## MAGNUM VENUS PRODUCTS

HIGH VOLUME PRO GUN WITH ELECTRIC OPERATOR VALVE

CPHV-1000-EP

REV:

SHEET 2 / 2

4/12/2016

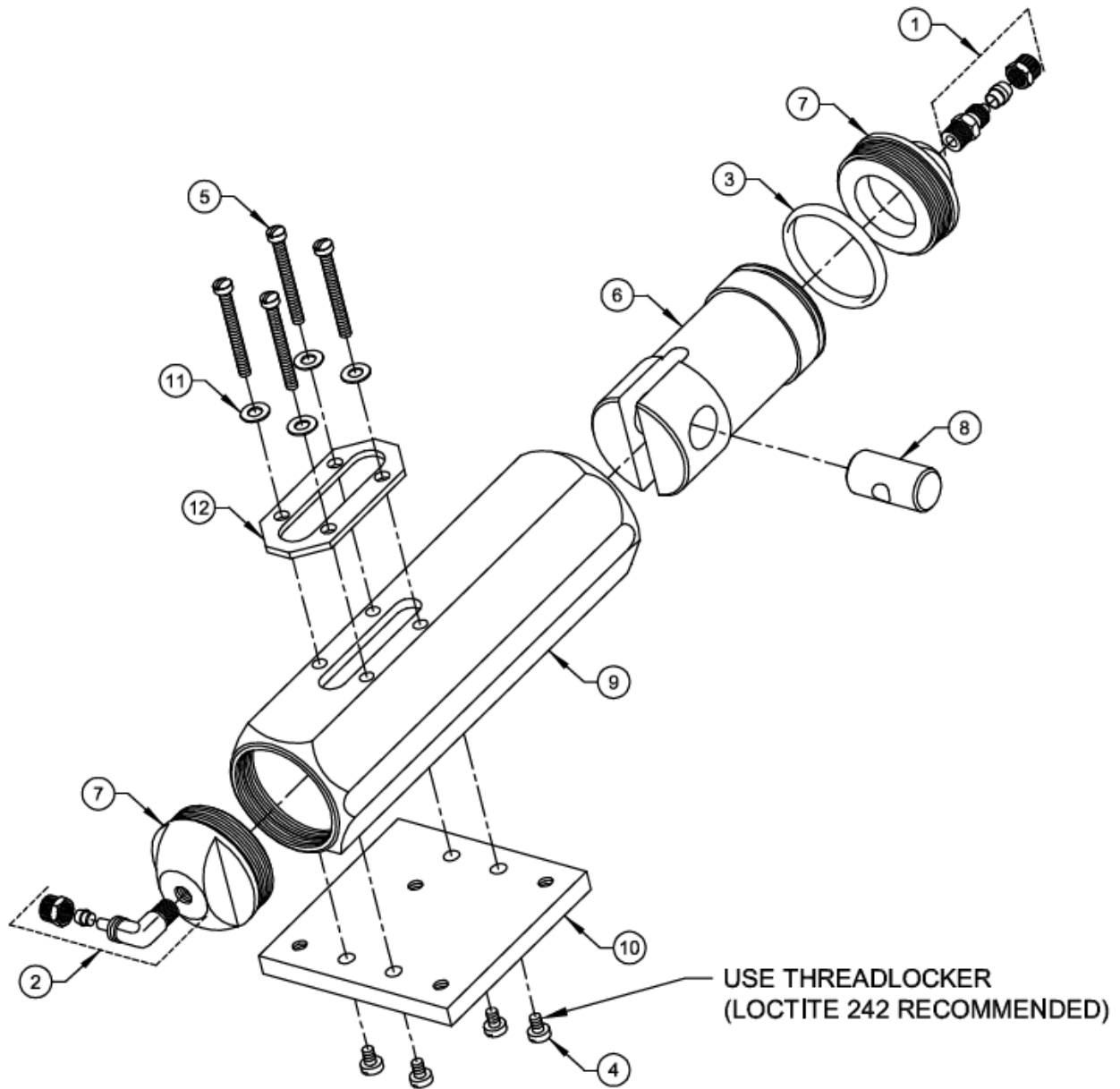

## MAGNUM VENUS PLASTECH

High Volume Pro Gun Actuator Assy

58103-1

REV. B = REDRAWN ON NEW FORM 2/27/06 JEM  
REV. C = UPDATED ITEMS 1-5 TO ALPHA NUMERIC, SYSTEM ONE NUMBERS, ITEM 3 WAS 02909-3 08/07/07 BT2  
REV. D = ADDED THREADLOCKER NOTE 11/04/08 BT2

---

**HV Pro Gun Actuator Assy****58103-1****PARTS LIST**

ITEM	PART NO.	QTY	DESCRIPTION
1	7701-6-14	1	MALE CONNECTOR
2	MPH-2534	1	MALE ELBOW
3	O-V-133	1	O-RING
4	02809-3	4	MACHINE SCREW
5	F-PH-04C-28	4	MACHINE SCREW
6	58136-1	1	ACTUATOR PISTON
7	58137-1	2	CYLINDER CAP
8	58138-1	1	ACTUATING BUSHING
9	58140-1	1	CYLINDER BODY
10	58141-1	1	MOUNTING PLATE
11	58143-1	4	SEAL
12	58144-1	1	ACTUATOR SEAL

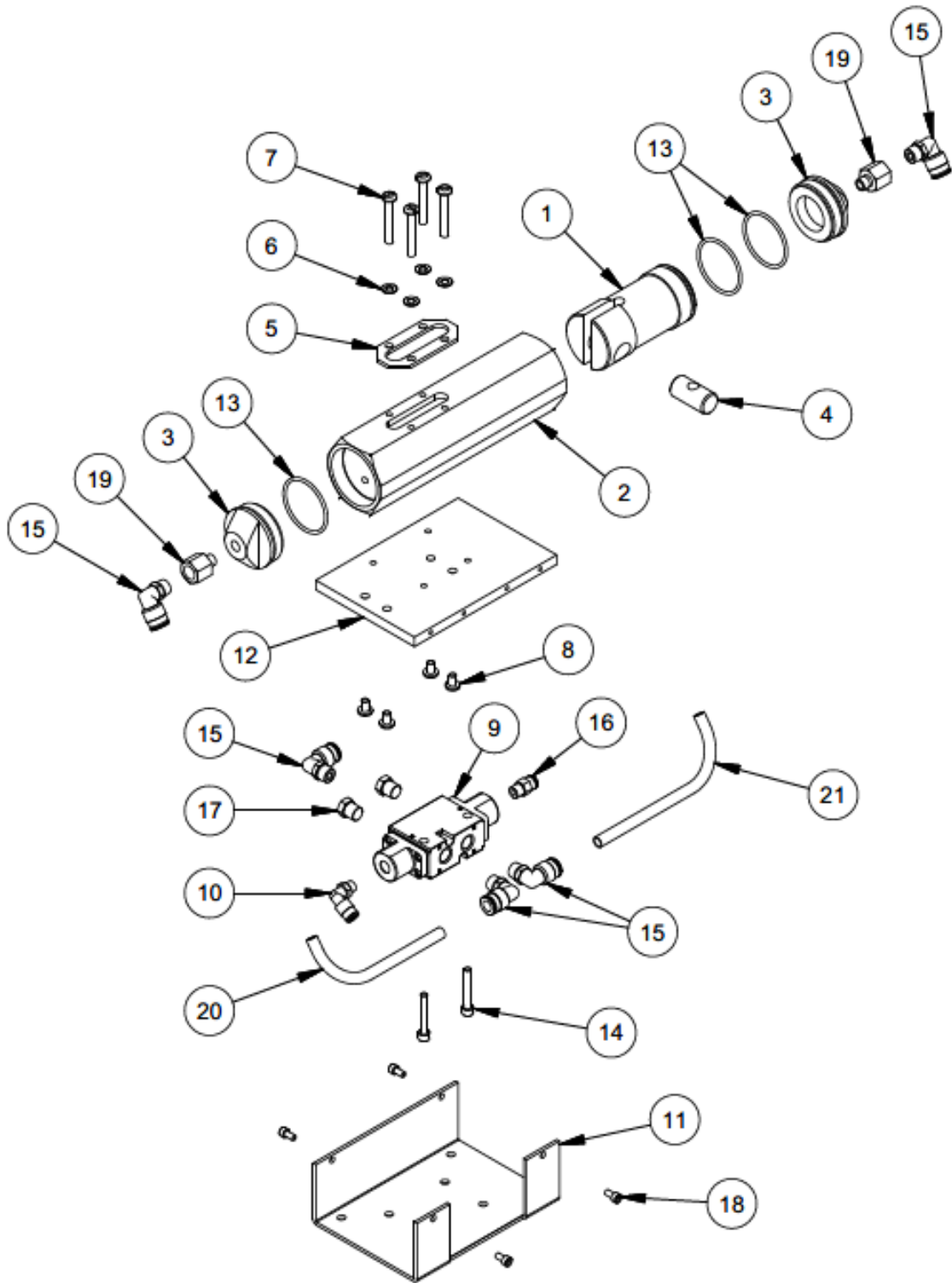

# MAGNUM VENUS PRODUCTS

HIGH VOLUME DUO GUN ACTUATOR ASSEMBLY	HVDG-4200
---------------------------------------	-----------

REV: A 03/30/2017

SHEET 1 / 2

11/12/2015



Parts List			
ITEM	PART NUMBER	QTY	DESCRIPTION
1	58136-1	1	ACTUATING PISTON
2	58140-1	1	ACTUATOR BODY
3	58137-1	2	END CAP
4	58138-1	1	ACTUATING BUSHING
5	58144-1	1	ACTUATOR SEAL
6	58143-1	4	MOUNTING SEAL
7	F-PH-04C-28	4	PAN HEAD SCREW
8	02809-3	4	PAN HEAD SCREW
9	HVDG-2226	1	MAC DUAL PILOT VALVE
10	MPH-2539	1	MALE ELBOW
11	HVDG-2221	1	VALVE COVER
12	HVDG-2222	1	MOUNTING PLATE
13	O-V-133	3	O-RING
14	F-CS-04C-24	2	CAP SCREW
15	07234	5	MALE POLY ELBOW
16	07223	1	MALE CONNECTOR
17	MPM-2568	2	BREATHER VENT
18	F-CS-1024-06	4	CAP SCREW
19	PF-RA-04-02	2	REDUCER ADAPTER
20	MPM-2583-1	.50 FT	TUBE
21	MPM-2583-1	.58 FT	TUBE

## MAGNUM VENUS PRODUCTS

HIGH VOLUME DUO GUN ACTUATOR ASSEMBLY

HVDG-4200

REV: A 03/30/2017

SHEET 2 / 2

11/12/2015



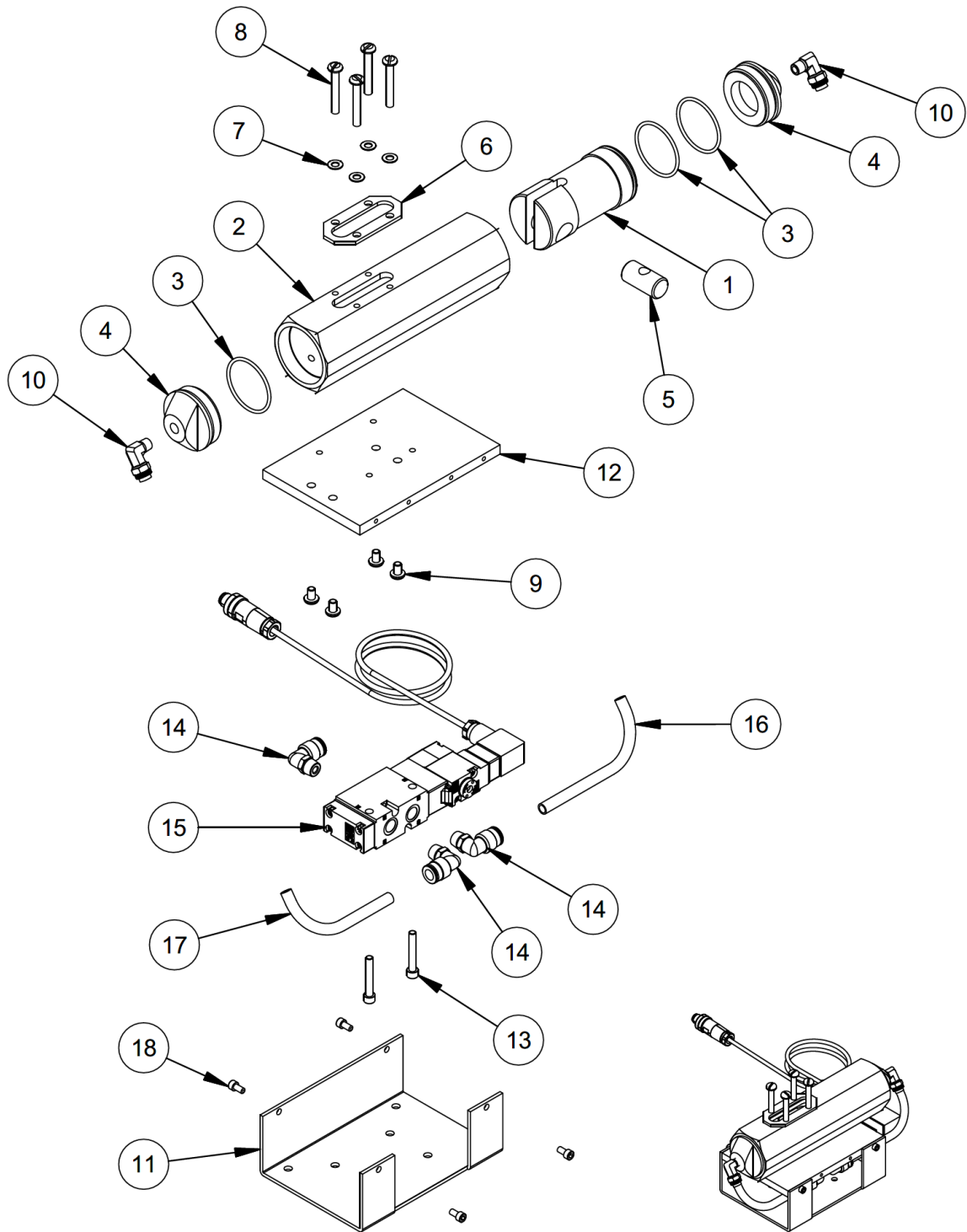

# MAGNUM VENUS PRODUCTS

GUN ACTUATOR ASSEMBLY	HVDG-4200-EP
-----------------------	--------------

REV:

SHEET 1 / 2

8/19/2015



Parts List			
ITEM	PART NUMBER	QTY	DESCRIPTION
1	58136-1	1	ACTUATING PISTON
2	58140-1	1	ACTUATOR BODY
3	O-V-133	3	O-RING
4	58137-1	2	END CAP
5	58138-1	1	ACTUATING BUSHING
6	58144-1	1	ACTUATOR SEAL
7	58143-1	4	MOUNTING SEAL
8	F-PH-04C-28	4	PAN HEAD SCREW
9	02809-3	4	PAN HEAD SCREW
10	7701-6-18	2	POLY TUBE ELBOW
11	HVDG-2221	1	VALVE COVER
12	HVDG-2222	1	MOUNTING PLATE
13	F-CS-04C-24	2	CAP SCREW
14	07234	3	MALE POLY ELBOW
15	PV-103	1	24VDC VALVE ASSEMBLY .250 INCH, 4-3
16	MPM-2583-1	.5 FT	TUBE
17	MPM-2583-1	.5 FT	TUBE
18	F-CS-1024-06	4	CAP SCREW

# MAGNUM VENUS PRODUCTS

GUN ACTUATOR ASSEMBLY

HVDG-4200-EP

REV:

SHEET 2 / 2

8/19/2015



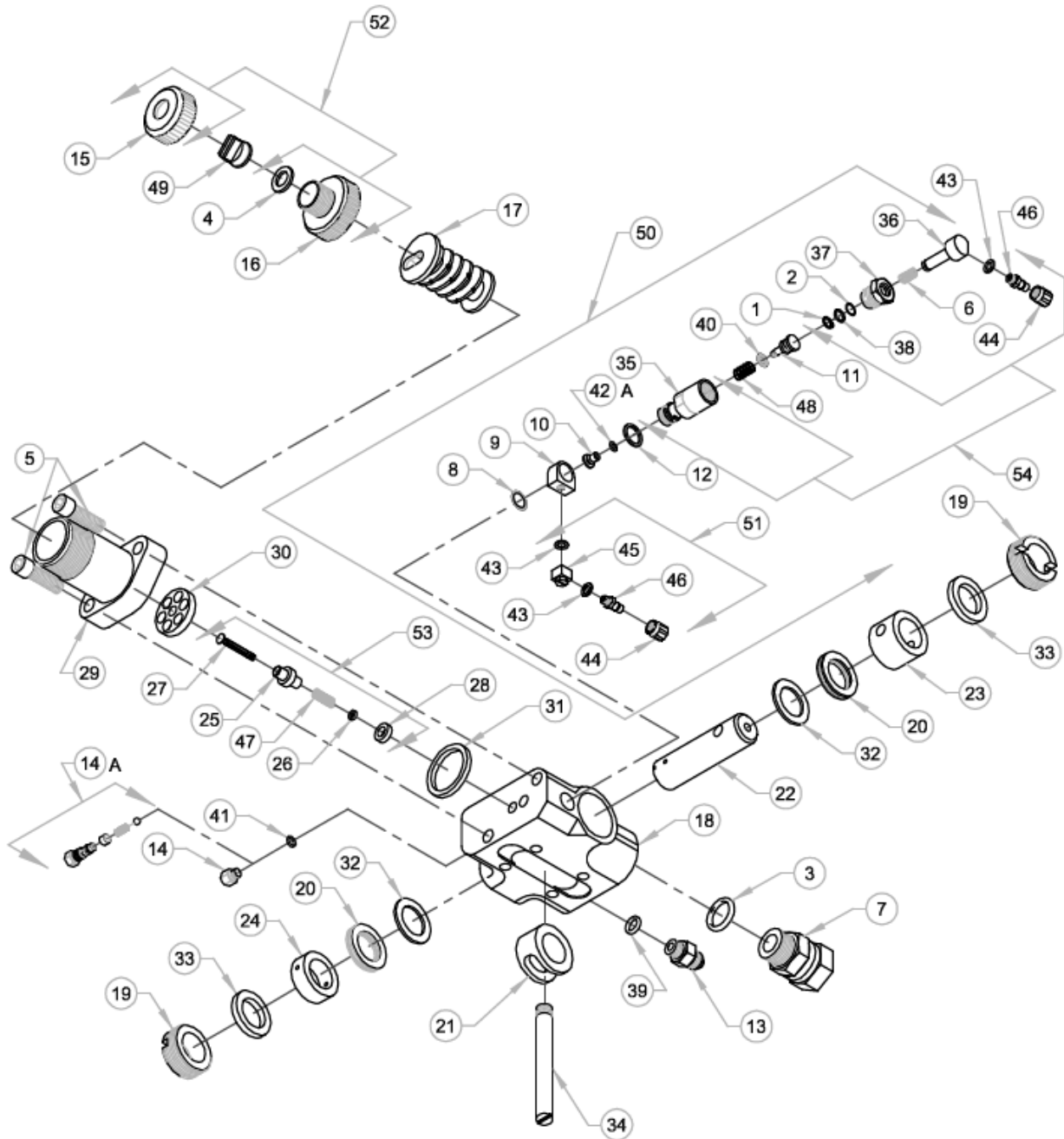

## MAGNUM VENUS PLASTECH

ASSY - HV PRO GUN BLOCK  
 ASSY - HV PRO GUN BLOCK

58106-1  
 58106-1-INT

REV. G = ADDED REPAIR KIT 58110-1 TO DWG 08/05/04 JEM  
 REV. H = ITEM 40 WAS O-S-008A 08/02/04 BTZ  
 REV. I = UPDATED TO ALPHA-NUMERIC, CORRECTED ILLUSTRATION FOR ITEM 22 08/07/11 BTZ  
 REV. J = ADDED AVAILABLE TOOLS 01/22/14 BTZ

**ASSY - HV PRO GUN BLOCK 58106-1**  
**ASSY - HV PRO GUN BLOCK 58106-1-INT**

**PARTS LIST**

ITEM	PART NO.	QTY	DESCRIPTION
1	00973	1	GRIP RING
2	O-B-010	1	O-RING
3	O-V-3-908	1	O-RING
4	02149-1	1	NOZZLE SEAL - POUR MIXER
5	F-CS-05F-16-GR8	2	SOCKET HEAD CAP SCREW
6	04356	1	COMPRESSION SPRING
7	05654	1	FITTING
8	5104-21-1	1	FLUSH VALVE SPLIT SEAL
9	5104-22-1	1	FLUSH VALVE NECK
10	5104-23-1	1	FLUSH SEAL BODY
11	5104-25-1	1	FLUSH VALVE BUTTON
12	5104-26-1	1	FLUSH VALVE SEAL
13	7701-3-6	1	CATALYST FITTING
15	54800-1	1	NOZZLE CAP
16	54830-1	1	HV NOZZLE ADAPTOR
17	55010-1	1	TURBULENT MIXER
18	58121-1	1	HV PRO GUN BLOCK
19	58122-1	2	PACKING NUT
20	58123-1	2	RELIEF SPACER
21	58124-1	1	CENTER SPACER
22	58125-1	1	VALVE ROD
23	58126-1	1	RESIN SEAL
24	58127-1	1	CATALYST SEAL
25	58128-1	1	INJECTOR BODY
26	58129-1	1	PLUNGER RETAINER
27	58130-1	1	INJECTOR PLUNGER
28	58131-1	1	INJECTOR SEAL
29	58132-1	1	MIX HOUSING
30	58133-1	1	DISTRIBUTION RING
31	58134-1	1	MIX HOUSING SEAL
32	58135-1	2	SECONDARY SEAL
33	58146-1	2	PACKING RING
34	58147-1	1	ACTUATOR STEM
35	58681-1	1	AUTOMATIC FLUSH VALVE BODY
36	58716-1	1	PUSH STEM - AUTO/MANUAL FLUSH
37	58717-1	1	FLUSH BODY - AUTO/MANUAL
38	58718-1	1	BACK-UP RING - PUSH BUTTON
39	O-S-3-903	1	O-RING
40	O-E-008	1	O-RING *DO NOT GREASE THIS O-RING*
41	O-S-5-125	1	O-RING
43	7304-3-1	3	SEAL
44	7701-2-1	2	HOSE CLAMP
45	TRU-1021	1	EBOW FITTING
46	7701-6-3	2	BARBED FITTING
47	04354	1	COMPRESSION SPRING
48	9203-2-3	1	COMPRESSION SPRING
49	N-5010C	1	CARBIDE SPRAY NOZZLE

**REPAIR KITS**

PART NO.	DESCRIPTION
58110-1	HV PRO GUN REPAIR KIT

**AVAILABLE TOOLS**

PART NO.	DESCRIPTION
58198-1	SEAL INSTALLATION TOOL
58199-1	PACKING TOOL

**ASSY - HV PRO GUN BLOCK 58106-1**

ITEM	PART NO.	QTY	DESCRIPTION
14	5104-32-1	1	PLUG
42	O-E-007	1	O-RING

**ASSY - HV PRO GUN BLOCK 58106-1-INT**

ITEM	PART NO.	QTY	DESCRIPTION
14A	5104-04-01	1	CAT CHECK VALVE
42A	O-A-007	1	O-RING

**OPTIONAL PARTS AND ASSEMBLIES**

ITEM	PART NO.	QTY	DESCRIPTION
40B	O-K-008	1	O - RING
50	58742-1	1	FLUSH VALVE ASSEMBLY
51	5104-02-01	1	FLUSH ELBOW ASSEMBLY
52	54820-1	1	NOZZLE CAP ASSEMBLY
53	58115-1	1	INJECTOR ASSEMBLY
54	58715-1	1	AUTO/MANUAL FLUSH BUTTON ASSEMBLY

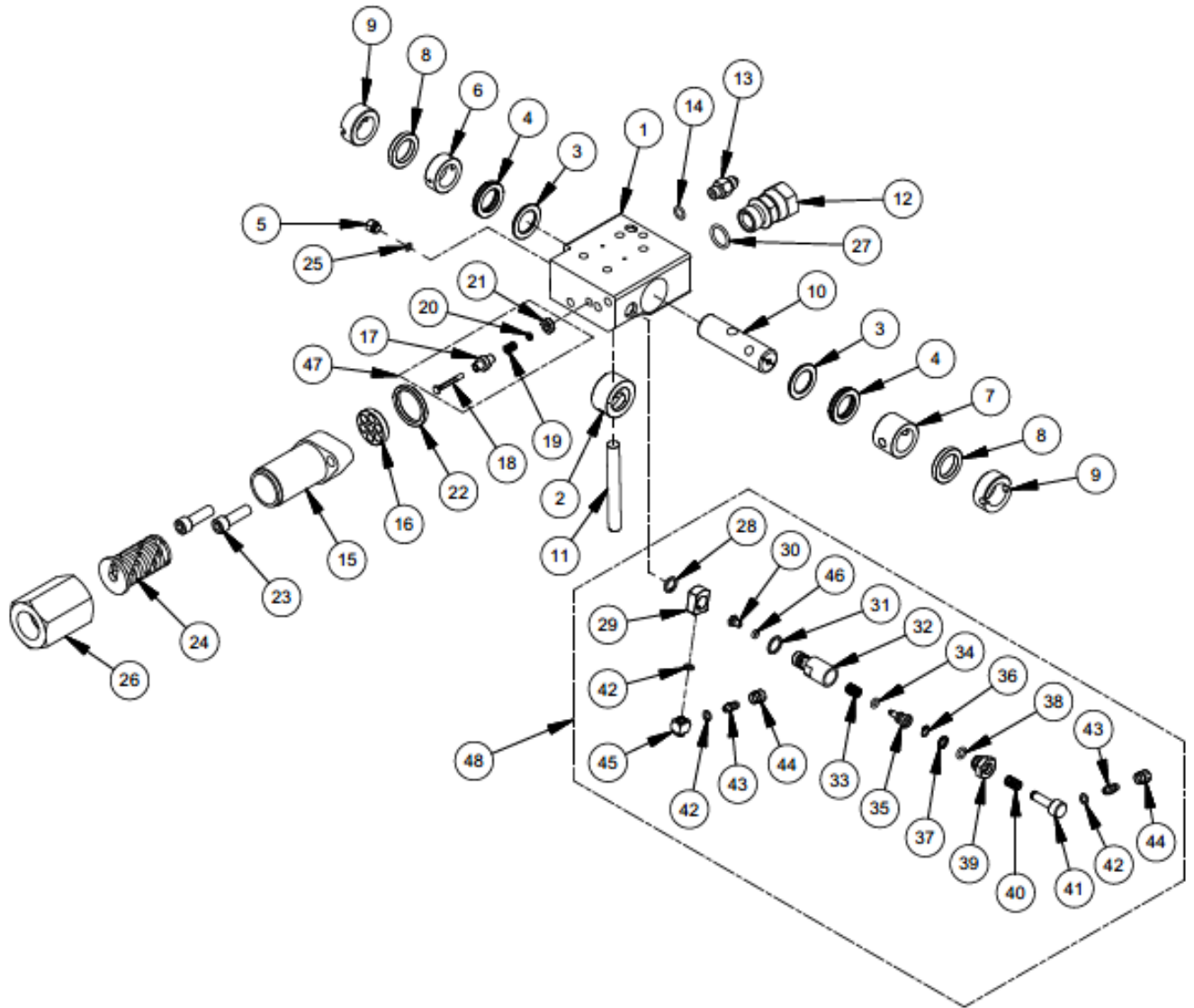

# MAGNUM VENUS PRODUCTS

HIGH VOLUME PRO GUN BLOCK ASSEMBLY

CPHV-1100

REV:

SHEET 1 / 2

4/12/2016

Parts List			
ITEM	PART NUMBER	QTY	DESCRIPTION
1	58121-1	1	HIGH VOLUME GUN BLOCK
2	58124-1	1	CENTER SPACER
3	58135-1	2	SECONDARY SEAL
4	58123-1	2	RELIEF SPACER
5	5104-32-1	1	PLUG
6	58127-1	1	CATALYST SEAL HV PRO GUN
7	58126-1	1	RESIN SEAL
8	58146-1	2	PACKING RING
9	58122-1	2	PACKING NUT
10	58125-1	1	VALVE ROD
11	58147-1	1	STEM
12	05654	1	SWIVEL FITTING
13	7701-3-6	1	CONNECTOR FITTING
14	O-S-3-903	1	O-RING
15	58132-1	1	MIX HOUSING
16	58133-1	1	DISTRIBUTION RING
17	58128-1	1	INJECTOR BODY HV PRO GUN
18	58130-1	1	INJECTOR PLUNGER HV PRO GUN
19	04354	1	INJECTOR SPRING HV PRO GUN
20	58129-1	1	RETAINER PLUNGER HV PRO GUN
21	58131-1	1	INJECTOR SEAL
22	58134-1	1	SEAL MIX HOUSING
23	F-CS-05F-16-GR8	2	SOCKET HEAD CAP SCREW
24	55010-1	1	HV TURBULENT MIXER
25	O-S-5-125	1	O-RING
26	54861-1	1	UNION
27	O-V-3-908	1	O-RING
28	5104-21-1	1	FLUSH VALVE SPLIT SEAL
29	5104-22-1	1	FLUSH VALVE NECK
30	5104-23-1	1	FLUSH SEAL BODY
31	5104-26-1	1	FLUSH VALVE SEAL
32	58681-1	1	FLUSH VALVE BODY
33	9203-2-3	1	COMPRESSION SPRING
34	O-E-008	1	O-RING
35	5104-25-1	1	FLUSH VALVE BUTTON
36	00973	1	INTERNAL SNAP RING
37	58718-1	1	BACKUP RING - AUTO FLUSH
38	O-B-010	1	O-RING
39	58717-1	1	FLUSH BODY
40	04356	1	COMPRESSION SPRING
41	58716-1	1	PUSH STEM
42	7304-3-1	3	NYLON SEAL
43	7701-6-3	2	10-32 BARBED FITTING
44	7701-2-1	2	HOSE CLAMP - POLY TUBE
45	TRU-1021	1	SWIVEL ELBOW FITTING
46	O-E-007	1	O-RING

## AVAILABLE SEPARATELY

47	58115-1	INJECTOR ASSEMBLY
48	58742-1	AUTO FLUSH VALVE ASSEMBLY

## MAGNUM VENUS PRODUCTS

HIGH VOLUME PRO GUN BLOCK ASSEMBLY

CPHV-1100

REV:

SHEET 2 / 2

4/12/2016



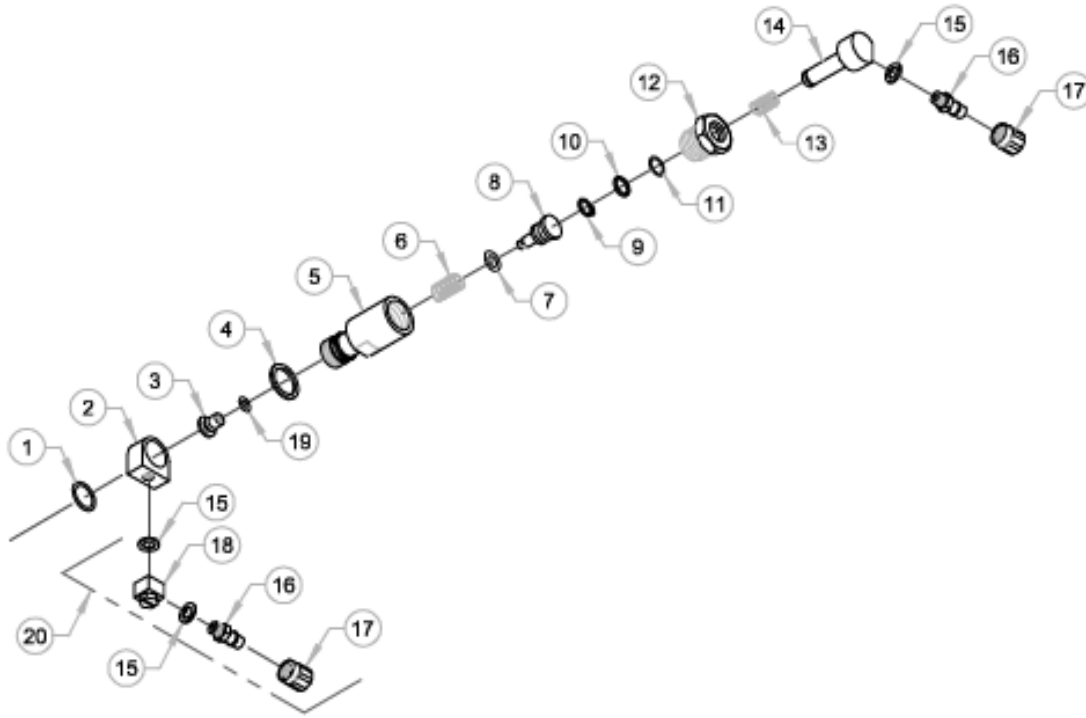

## MAGNUM VENUS PLASTECH

Automatic Flush Valve Assembly

58742-1

REV - 08-11-07 BT2  
REV A - ADDED THREADLOCKER NOTE 10-12-08 BT2  
REV B - REMOVED THREADLOCKER NOTE 11-23-13 BT2

Automatic Flush Valve Assembly 58742-1

**PARTS LIST**

ITEM	PART NO.	QTY	DESCRIPTION
1	5104-21-1	1	FLUSH VALVE SPLIT SEAL
2	5104-22-1	1	FLUSH VALVE NECK
3	5104-23-1	1	FLUSH SEAL BODY
4	5104-26-1	1	FLUSH VALVE SEAL
5	58681-1	1	FLUSH VALVE BODY
6	9203-2-3	1	COMPRESSION SPRING
7	O-E-008	1	O-RING
8	5104-25-1	1	FLUSH VALVE BUTTON
9	00973	1	GRIP RING
10	58718-1	1	BACK UP RING
11	O-B-010	1	O-RING
12	58717-1	1	MANUAL / AUTO FLUSH BODY
13	04356	1	SPRING
14	58716-1	1	PUSH STEM
15	7304-3-1	3	NYLON SEAL
16	7701-6-3	2	BARB FITTING
17	7701-2-1	2	HOSE CLAMP
18	TRU-1021	1	ELBOW FITTING
19	O-E-007	1	O-RING

**OPTIONAL PARTS AND ASSEMBLIES**

ITEM	PART NO.	QTY	DESCRIPTION
20	5104-02-01	1	FLUSH ELBOW ASSEMBLY

FIGURE 1-1



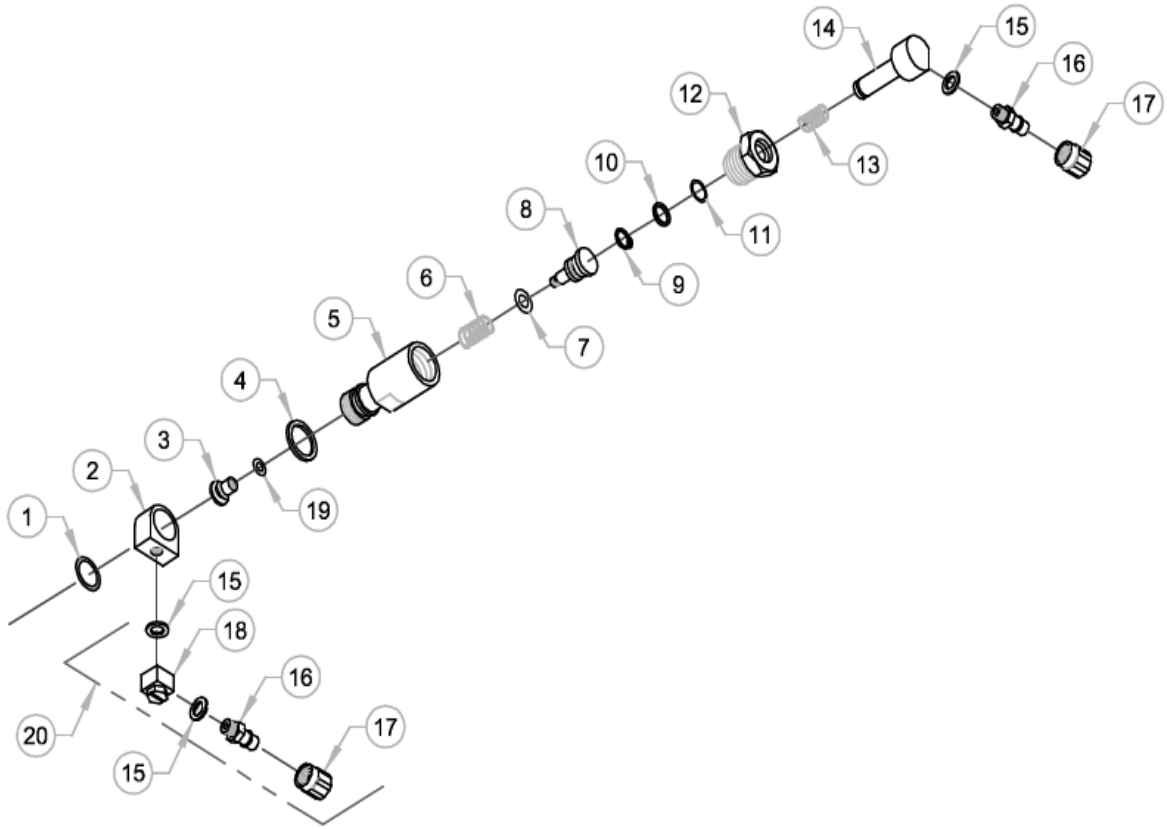

# MAGNUM VENUS PLASTECH

Automatic Flush Valve Assembly

58742-1-INT

REV - 07-19-10 BT2  
REV A - REMOVED THREADLOCKER NOTE 11-23-13 BT2

Automatic Flush Valve Assembly 58742-1-INT

PARTS LIST

ITEM	PART NO.	QTY	DESCRIPTION
1	5104-21-1	1	FLUSH VALVE SPLIT SEAL
2	5104-22-1	1	FLUSH VALVE NECK
3	5104-23-1	1	FLUSH SEAL BODY
4	5104-26-1	1	FLUSH VALVE SEAL
5	58681-1	1	FLUSH VALVE BODY
6	9203-2-3	1	COMPRESSION SPRING
7	O-E-008	1	O-RING
8	5104-25-1	1	FLUSH VALVE BUTTON
9	00973	1	GRIP RING
10	58718-1	1	BACK UP RING
11	O-B-010	1	O-RING
12	58717-1	1	MANUAL / AUTO FLUSH BODY
13	04356	1	SPRING
14	58716-1	1	PUSH STEM
15	7304-3-1	3	NYLON SEAL
16	7701-6-3	2	BARB FITTING
17	7701-2-1	2	HOSE CLAMP
18	TRU-1021	1	ELBOW FITTING
19	O-A-007	1	O-RING

OPTIONAL PARTS AND ASSEMBLIES

ITEM	PART NO.	QTY	DESCRIPTION
20	5104-02-01	1	FLUSH ELBOW ASSEMBLY

FIGURE 1-1



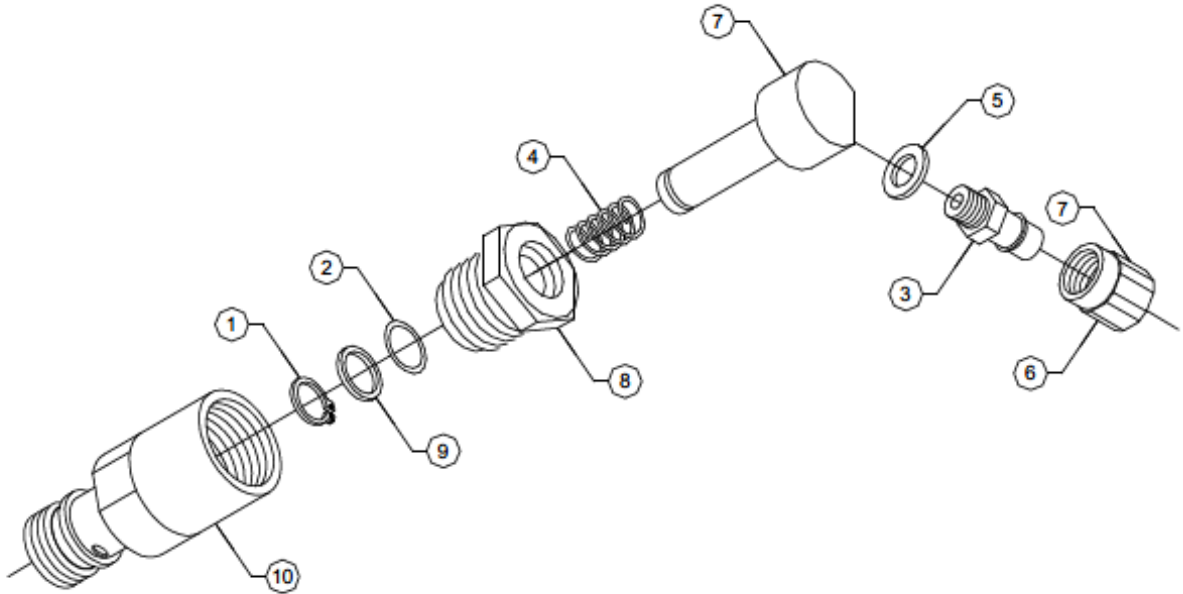

## MAGNUM VENUS PRODUCTS

Manual / Auto Flush Button Assy - Pro Gun

58715-1

REV. B = DWG CHANGED TO NEW FORM, ADDED 58681-1 TO DWG 4/11/03 JEM

**Manual / Auto Flush Button Assy - Pro Gun 58715-1**

**PARTS LIST**

ITEM	PART NO.	QTY	DESCRIPTION
1	00973	1	GRIP RING
2	01019	1	O-RING
3	7701-6-3	1	BARBED FITTING
4	04356	1	SPRING
5	7304-3-1	1	NYLON SEAL
6	7701-2-1	1	HOSE CLAMP
7	58716-1	1	PUSH STEM
8	58717-1	1	BODY - AUTO FLUSH VALVE
9	58718-1	1	BACK UP RING
10	58681-1	1	BODY - FLUSH VALVE

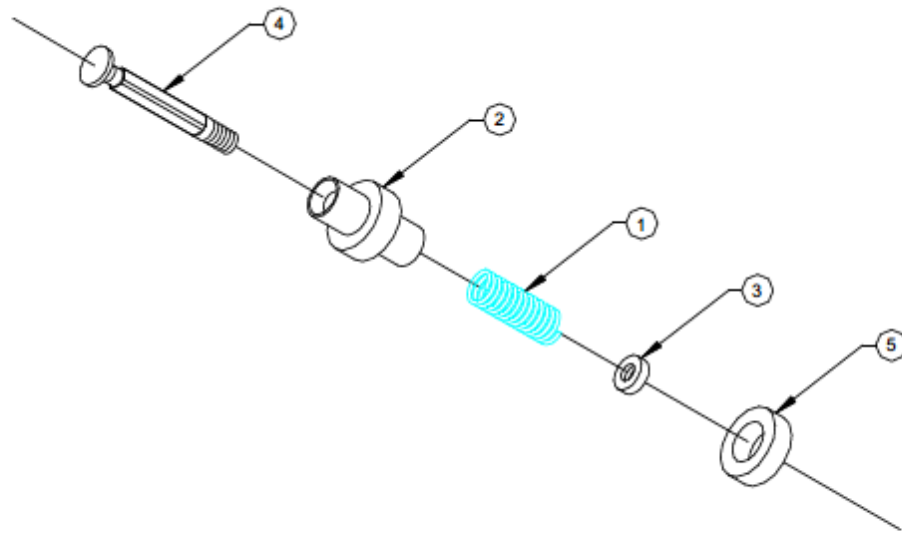

**MAGNUM VENUS PRODUCTS**

INJECTOR ASSY - HV PRO GUN

58115-1

REV. -- 1/14/03 JEM

INJECTOR ASSY - HV PRO GUN 58115-1

PARTS LIST

ITEM	PART NO.	QTY	DESCRIPTION
1	04354	1	COMPRESSION SPRING
2	58128-1	1	INJECTOR BODY
3	58129-1	1	PLUNGER RETAINER
4	58130-1	1	INJECTOR PLUNGER
5	58131-1	1	INJECTOR SEAL

FIGURE 1-1

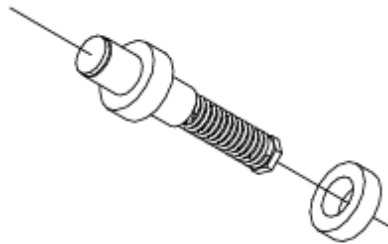

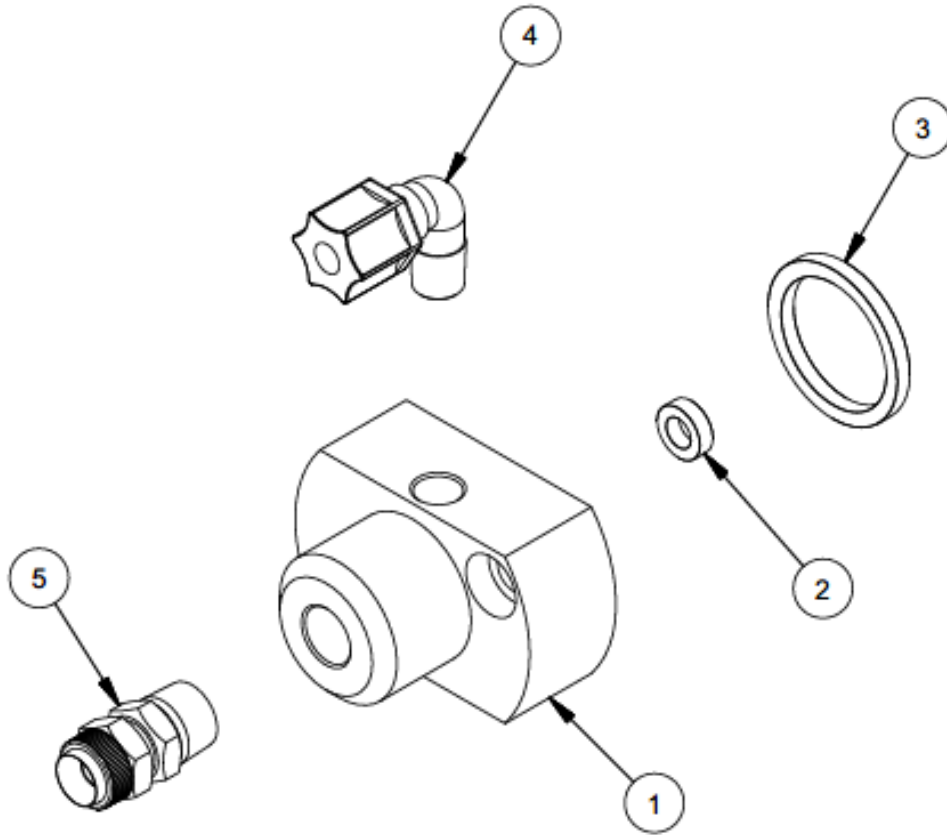

# MAGNUM VENUS PLASTECH

RATIO TEST KIT FOR HIGH VOLUME PRO GUN

PRO-HV-TT

REV:

SHEET 1 / 2

12/26/2013

Parts List			
ITEM	PART NUMBER	QTY	DESCRIPTION
1	58139-1	1	RATIO BLOCK
2	58131-1	1	INJECTOR SEAL
3	58134-1	1	SEAL MIX HOUSING
4	MS-2053	1	MALE ELBOW - TUBE
5	7701-3-35	1	MALE CONNECTOR

# MAGNUM VENUS PLASTECH

RATIO TEST KIT FOR HIGH VOLUME PRO GUN

PRO-HV-TT

REV:

SHEET 2 / 2

12/26/2013



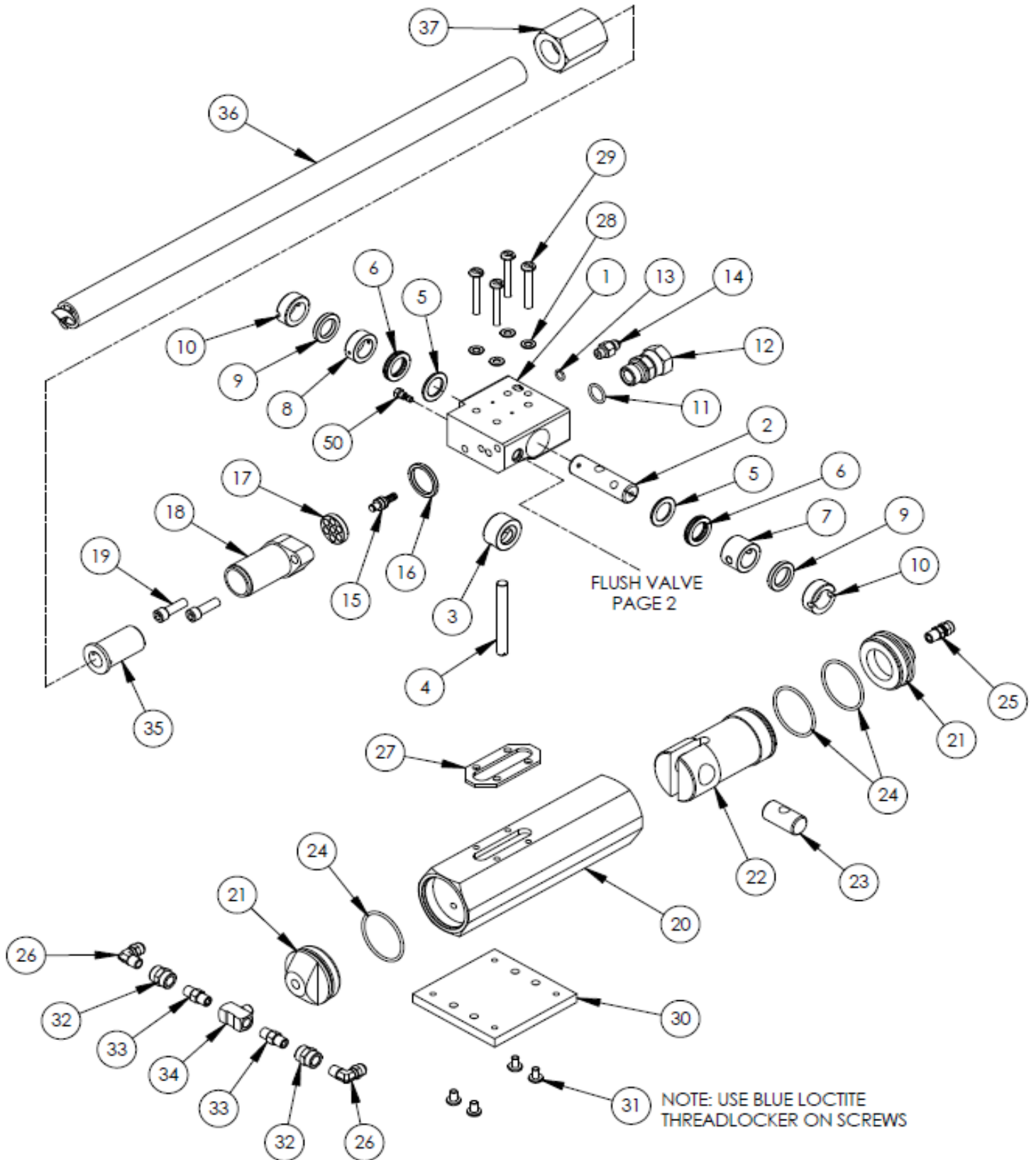

# MAGNUM VENUS PRODUCTS

HIGH VOLUME AUTOMATIC PRO GUN

HVPRO-2000-A

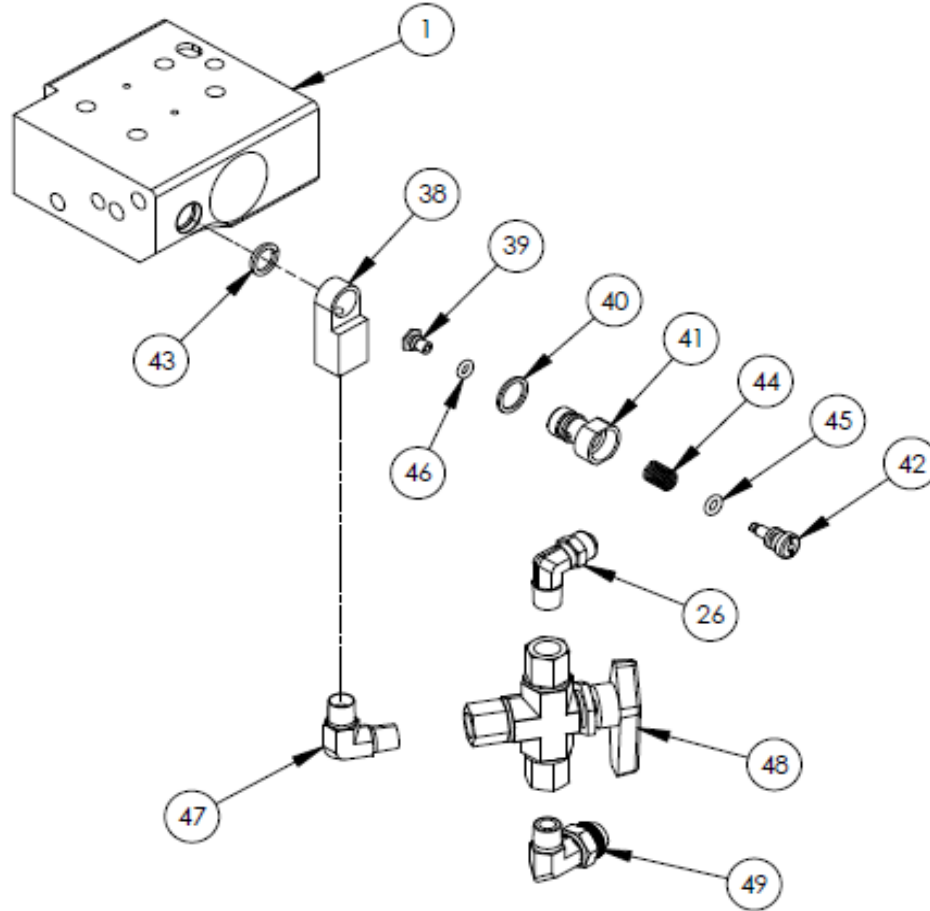

Parts List			
ITEM	PART NUMBER	QTY	DESCRIPTION
1	58121-1	1	HIGH VOLUME GUN BLOCK
2	58125-1	1	VALVE ROD
3	58124-1	1	CENTER SPACER
4	58147-1	1	STEM
5	58135-1	2	SECONDARY SEAL
6	58123-1	2	RELIEF SPACER
7	58126-1	1	RESIN SEAL
8	58127-1	1	CATALYST SEAL
9	58146-1	2	PACKING RING
10	58122-1	2	PACKING NUT
11	O-V-3-908	1	O-RING
12	05654	1	SWIVEL FITTING
13	O-S-3-903	1	O-RING
14	7701-3-6	1	CONNECTOR FITTING
15	58115-1	1	INJECTOR ASSY, HV PROGUN

# MAGNUM VENUS PRODUCTS

HIGH VOLUME AUTOMATIC PRO GUN

HVPRO-2000-A

Parts List			
ITEM	PART NUMBER	QTY	DESCRIPTION
16	58134-1	1	SEAL MIX HOUSING
17	58133-1	1	DISTRIBUTION RING
18	58132-1	1	MIX HOUSING
19	F-CS-05F-16-GR8	2	CAP SCREW
20	58140-1	1	ACTUATOR BODY
21	58137-1	2	END CAP
22	58136-1	1	ACTUATING PISTON
23	58138-1	1	ACTUATING BUSHING
24	O-V-133	3	O-RING
25	7701-6-14	1	STRAIGHT POLY FITTING
26	MPH-2534	3	POLY ELBOW
27	58144-1	1	ACTUATOR SEAL
28	58143-1	4	MOUNTING SEAL
29	F-PH-04C-28	4	PAN HEAD SCREW
30	58141-1	1	MOUNT PLATE
31	02809-3	4	PAN HEAD SCREW
32	PF-FC-02	2	1/8 NPT COUPLING
33	PF-HN-02	2	HEX NIPPLE
34	PF-MBT-02-02	1	MALE BRANCH TEE
35	55011-1	1	MIXER PLUG
36	05260	1	MIXER TUBE
37	54861-1	1	UNION
38	5104-22-2	1	FLUSH VALVE NECK
39	5104-23-1	1	FLUSH SEAL BODY
40	5104-26-1	1	FLUSH VALVE SEAL
41	5104-24-1	1	FLUSH VALVE BODY
42	5104-25-1	1	FLUSH VALVE BUTTON
43	5104-21-1	1	FLUSH VALVE SPLIT SEAL
44	9203-2-3	1	COMPRESSION SPRING
45	O-E-008	1	O-RING
46	O-A-007	1	O-RING
47	PF-ME-02-SS	1	ELBOW
48	8407-6-1	1	BALL VALVE - SS
49	7701-6-18	1	POLY TUBE ELBOW
50	5104-04-01	1	CHECK VALVE ASSEMBLY

## MAGNUM VENUS PRODUCTS

HIGH VOLUME AUTOMATIC PRO GUN

HVPRO-2000-A

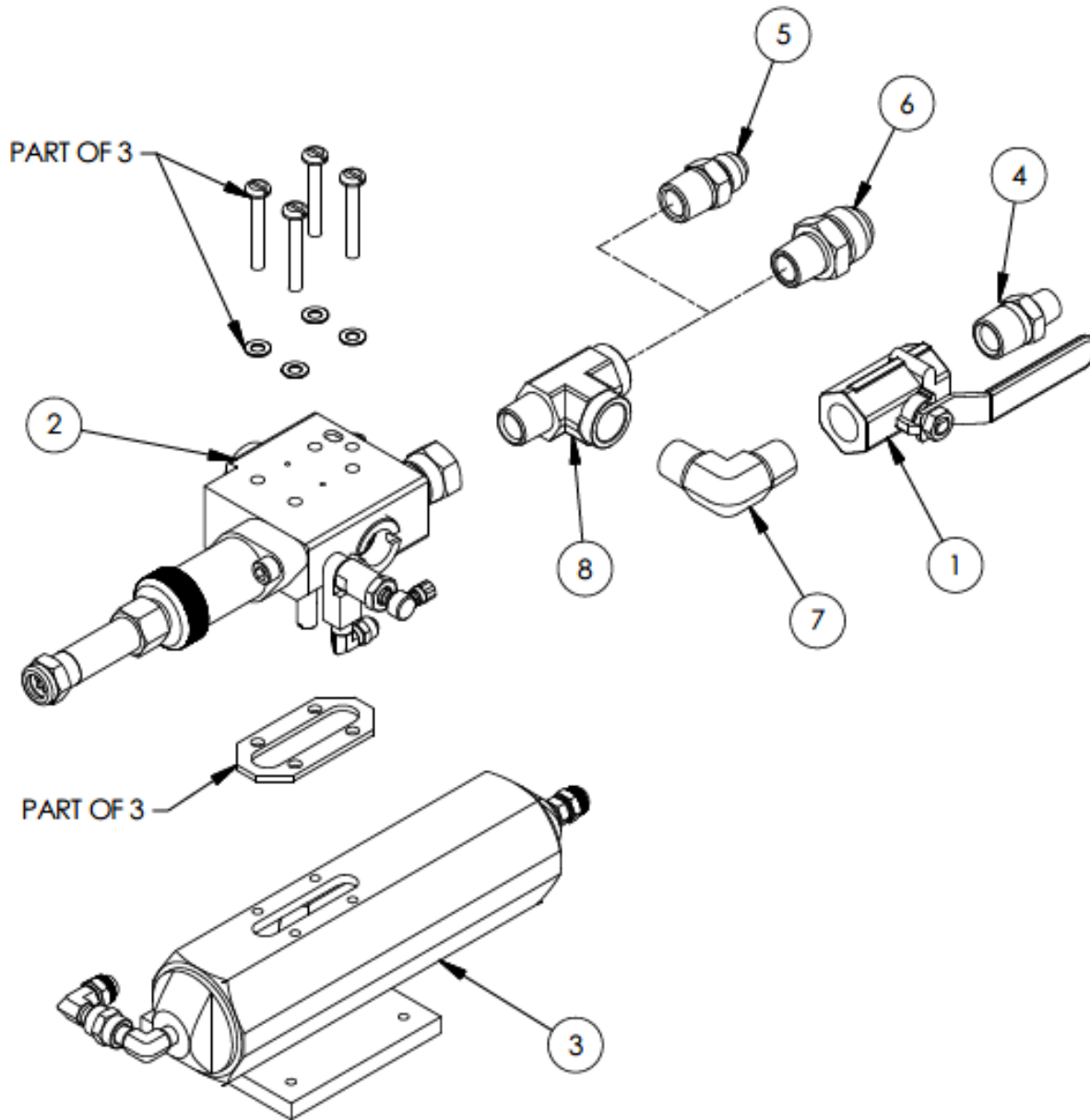

# MAGNUM VENUS PRODUCTS

HIGH VOLUME PRO GUN

CPHV-2000

REV: -

SHEET 1 / 2

3/8/2018

Parts List			
ITEM	PART NUMBER	QTY	DESCRIPTION
1	BV-88-HP	1	BALL VALVE
2	CPHV-2100	1	GUN BLOCK ASSEMBLY
3	CPHV-2200	1	ACTUATOR ASSY
4	PF-HN-08-06	1	HEX NIPPLE
5	PF-HN-08-08J	1	HOSE ADAPTER
6	PF-HN-08-12J	1	HOSE ADAPTER
7	PF-ME-08	1	MALE ELBOW
8	PF-ST-08	1	STREET TEE

# MAGNUM VENUS PRODUCTS

HIGH VOLUME PRO GUN

CPHV-2000













REV: -

SHEET 2 / 2



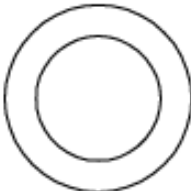

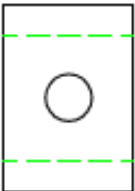
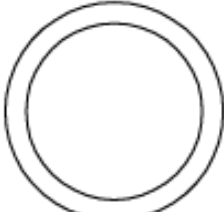
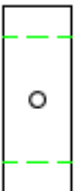







3/8/2018





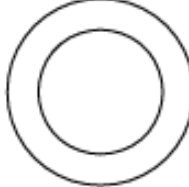
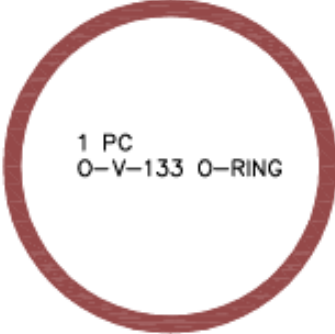
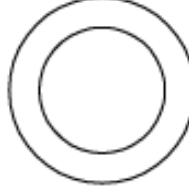

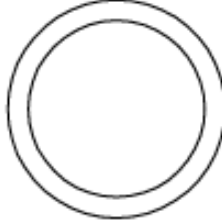









58110-1  
HV PRO GUN REPAIR KIT

- |      |   |  |       |  |                            |
|------|---|--|-------|--|----------------------------|
| 1 PC |    | O-E-007 O-RING                                       | 5 PCS |     | 7304-3-1 NYLON SEAL        |
| 1 PC |    | O-E-008 O-RING<br><i>*DO NOT GREASE THIS O-RING*</i> | 1 PC  |     | 58131-1 INJECTOR SEAL      |
| 1 PC |    | O-S-5-125 O-RING                                     | 4 PCS |     | 58143-1 MOUNTING SEAL      |
| 1 PC |    | O-S-3-903 O-RING                                     | 1 PC  |    | 5104-26-1 FLUSH VALVE SEAL |
| 1 PC |    | O-V-3-908 O-RING                                     | 2 PCS |    | 58135-1 SECONDARY SEAL     |
|      |   | 1 PC<br>O-V-133 O-RING                               | 2 PCS |   | 58146-1 PACKING RING       |
| 1 PC |  | 58126-1 RESIN SEAL                                   | 1 PC  |  | 58134-1 MIX HOUSING SEAL   |
| 1 PC |  | 58127-1 CATALYST SEAL                                | 1 PC  |  | 5104-21-1 SPLIT SEAL       |

58110-1-INT  
REPAIR KIT – HV PRO GUN INTERNATIONAL

- |      |   |   |       |  |                            |
|------|---|---|-------|--|----------------------------|
| 1 PC |    | O-A-007 O-RING                                | 5 PCS |     | 7304-3-1 NYLON SEAL        |
| 1 PC |    | O-E-008 O-RING<br>*DO NOT GREASE THIS O-RING* | 1 PC  |     | 58131-1 INJECTOR SEAL      |
| 1 PC |    | O-S-5-125 O-RING                              | 4 PCS |     | 58143-1 MOUNTING SEAL      |
| 1 PC |    | O-S-3-903 O-RING                              | 1 PC  |     | 5104-26-1 FLUSH VALVE SEAL |
| 1 PC |    | O-V-3-908 O-RING                              | 2 PCS |    | 58135-1 SECONDARY SEAL     |
|      |   | 1 PC<br>O-V-133 O-RING                        | 2 PCS |   | 58146-1 PACKING RING       |
| 1 PC |  | 58126-1 RESIN SEAL                            | 1 PC  |  | 58134-1 MIX HOUSING SEAL   |
| 1 PC |  | 58127-1 CATALYST SEAL                         | 1 PC  |  | 5104-21-1 SPLIT SEAL       |

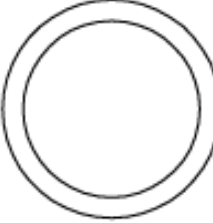
CPHV-1000-RK  
HV PRO GUN REPAIR KIT

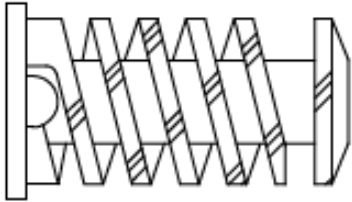
- |      |   |  |       |  |                            |
|------|---|--|-------|--|----------------------------|
| 1 PC |    | O-E-007 O-RING                                       | 3 PCS |     | 7304-3-1 NYLON SEAL        |
| 1 PC |    | O-E-008 O-RING<br><i>*DO NOT GREASE THIS O-RING*</i> | 1 PC  |     | 58131-1 INJECTOR SEAL      |
| 1 PC |    | O-S-5-125 O-RING                                     | 4 PCS |     | 58143-1 MOUNTING SEAL      |
| 1 PC |    | O-S-3-903 O-RING                                     | 1 PC  |     | 5104-26-1 FLUSH VALVE SEAL |
| 1 PC |    | O-V-3-908 O-RING                                     | 2 PCS |    | 58135-1 SECONDARY SEAL     |
|      |   | 3 PCS<br>O-V-133 O-RING                              | 2 PCS |   | 58146-1 PACKING RING       |
| 1 PC |  | 58126-1 RESIN SEAL                                   | 1 PC  |  | 58134-1 MIX HOUSING SEAL   |
| 1 PC |  | 58127-1 CATALYST SEAL                                | 1 PC  |   | 5104-21-1 SPLIT SEAL       |
|      |   |  | 1 PC  |   | 55010-1 TURBULENT MIXER    |