

NOTE:
INSTALL ZERK AFTER
SHAFT IS THRU
TOP PLATE

NOTE: A LIGHT COAT OF SUPER O LUBE IS RECOMMENDED
ON THE UPPER AND LOWER PILOT VALVES

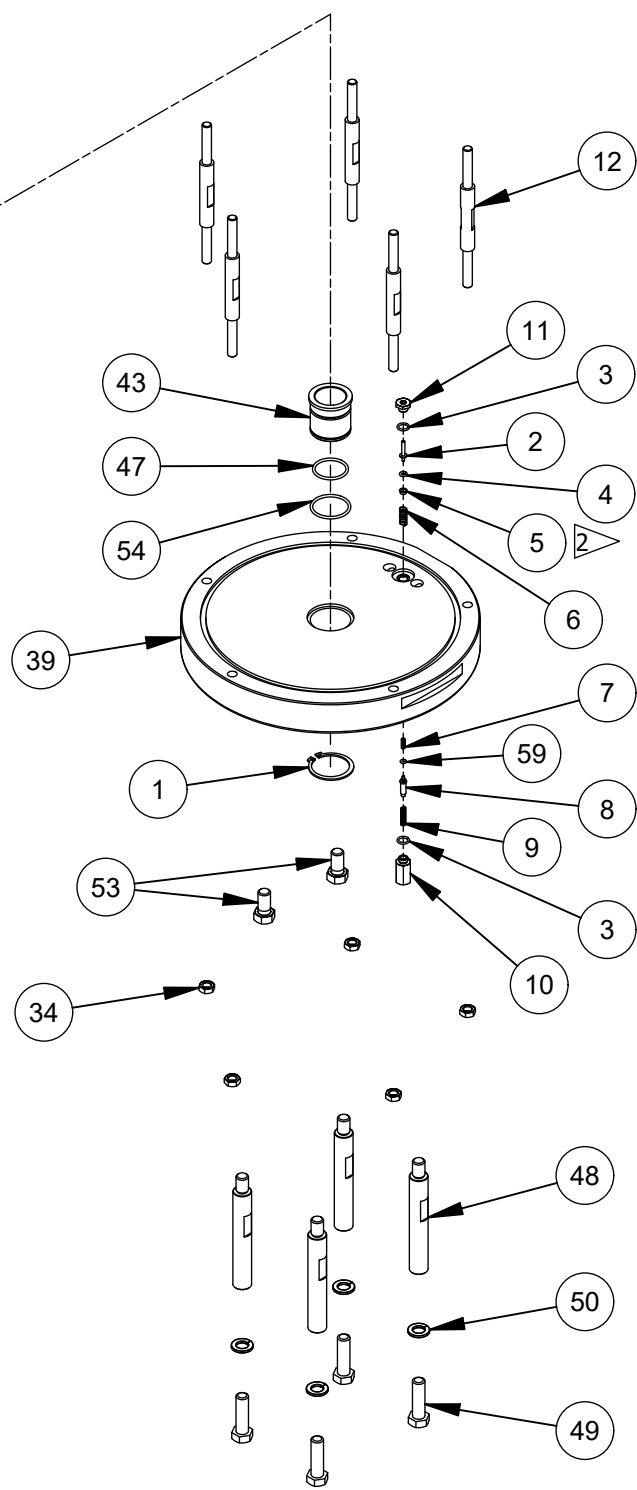

- ▶ USE REMOVABLE LOCTITE ON THREADS OF ITEM 52
- ▶ INSTALL ITEM 42 WITH COUNTERBORE DOWN
- ▶ INSTALL ITEM 5 WITH FLANGE UP
- ▶ INSTALL ITEM 5 WITH FLANGE DOWN

MAGNUM VENUS PRODUCTS

10" PATRIOT POWER HEAD	PAT-PH-10000
------------------------	--------------

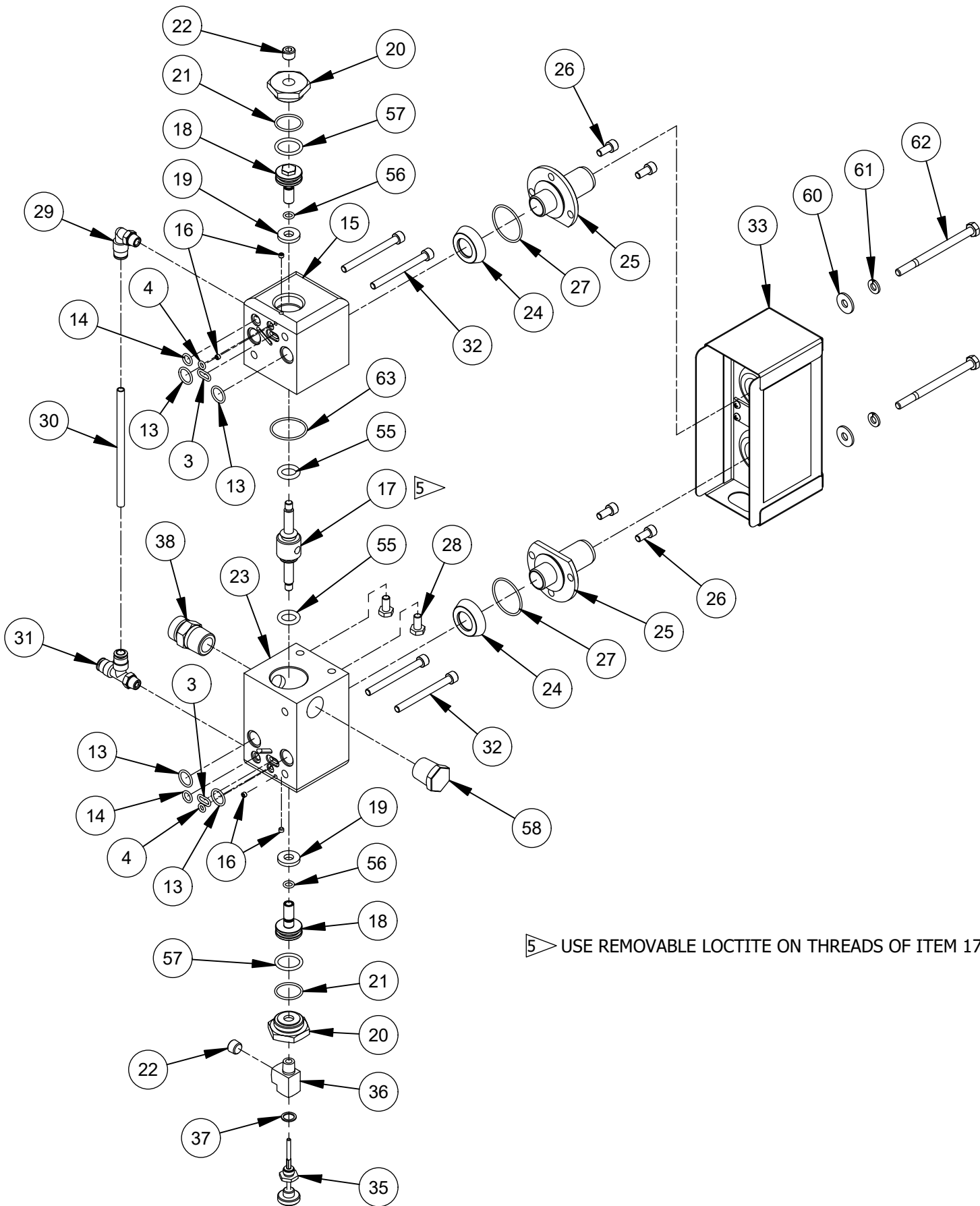

5 USE REMOVABLE LOCTITE ON THREADS OF ITEM 17

MAGNUM VENUS PRODUCTS

10" PATRIOT POWER HEAD	PAT-PH-10000
------------------------	--------------

Parts List			
ITEM	PART NUMBER	QTY	DESCRIPTION
1	7205-2-26	2	EXTERNAL SNAP RING
2	MPH-2513	2	VALVE STEM- PILOT VALVE
* 3	O-B-012	6	O-RING
* 4	O-B-008	4	O-RING
5	MPH-2512	2	SEAL GUIDE- PILOT VALVE
6	MPH-2528	2	SPRING
7	MPH-2526	2	SPRING
8	MPH-2540	2	INLET ROD- PILOT VALVE
9	MPH-2533	2	COMPRESSION SPRING
10	MPH-2541	2	SPRING HOUSING- PILOT VALVE
11	MPH-2511-01	2	STEM SEAL ASSY- PILOT VALVE
12	PAT-PH-5006	5	TIE ROD - 2" STROKE
* 13	O-B-014	4	O-RING
* 14	O-B-011	2	O-RING
15	PAT-PH-5001	1	UPPER VALVE BLOCK
16	F-SS-832-02-SS	4	SS SET SCREW
17	PAT-PH-5005	1	POPPET VALVE - 2" STROKE
18	MPH-2517	2	VALVE PISTON
19	MPH-3262	2	PISTON STOP
20	MPH-2521	2	VALVE END CAP
* 21	O-B-019	2	O-RING
22	PF-AP-02-SS	2	PIPE PLUG
23	PAT-PH-5002	1	LOWER VALVE BLOCK
* 24	MPH-5010	2	DIAPHRAGM
25	MPH-5009	2	EXHAUST PORT
26	F-CS-04C-08-SS	4	SOCKET HEAD CAP SCREW
* 27	O-B-026	2	O-RING
28	F-HB-04C-08	2	HEX BOLT
29	MPH-2539	1	MALE ELBOW
30	MS-2052-1	1	TUBING
31	MPH-2538	1	MALE POLY TEE FITTING
32	F-CS-04C-40-SS	4	SOCKET HEAD CAP SCREW
33	PAT-PH-5010-01	1	MUFFLER ASSEMBLY
34	F-HN-06F	10	HEX NUT
35	MPH-2546-01	1	RESET STEM ASSEMBLY
36	PF-ST-02-BR	1	TEE FITTING
37	MPH-2545	1	SEAL
38	PF-HN-08-08S	1	HEX NIPPLE
39	PAT-PH-10004	1	LOWER END CAP 10"
40	PAT-PH-10012	1	UPPER END CAP 10"
41	PAT-PH-10003	1	CYLINDER
42	VPH-10006	1	PISTON - 10" POWER HEAD
43	VPH-7005	2	BUSHING - UPPER PISTON ROD
* 44	O-B-445	2	O-RING
* 45	O-B-448	1	O-RING
* 46	O-B-178	2	O-RING
* 47	O-B-124	2	O-RING
48	PAT-PH-10011	4	TIE ROD
49	F-HB-08C-28-GR5	4	HEX BOLT
50	F-SW-08	4	LOCK WASHER
51	PAT-PH-10009	1	LOWER ROD
52	PAT-PH-10008	1	UPPER SHAFT ASSY

MAGNUM VENUS PRODUCTS

10" PATRIOT POWER HEAD

PAT-PH-10000

Parts List				
ITEM	PART NUMBER	QTY	DESCRIPTION	
	53	F-HB-08C-16	2	HEX BOLT - Inch
*	54	O-B-127	2	O-RING
*	55	O-U-206-90	2	O-RING
*	56	O-D-010-90	2	O-RING
*	57	O-B-116	2	O-RING
	58	PF-HP-08	1	HEX PLUG
*	59	O-U-006	2	O-RING
	60	F-FW-04	2	FLAT WASHER
	61	F-SW-04-SS	2	LOCK WASHER
	62	F-HB-04C-56-SS	2	HEX BOLT
*	63	O-B-024	1	O-RING
	64	05563	1	GREASE FITTING

* ASTERISKS DENOTE PARTS INCLUDED IN PAT-PH-10000-SK SEAL KIT

OPTIONAL PARTS AND ASSEMBLIES

PART No.	QTY.	DESCRIPTION
MPH-2542	1	RESET BUTTON ASSEMBLY
PAT-PH-SB-XL	1	SHIFT BLOCK ASSEMBLY

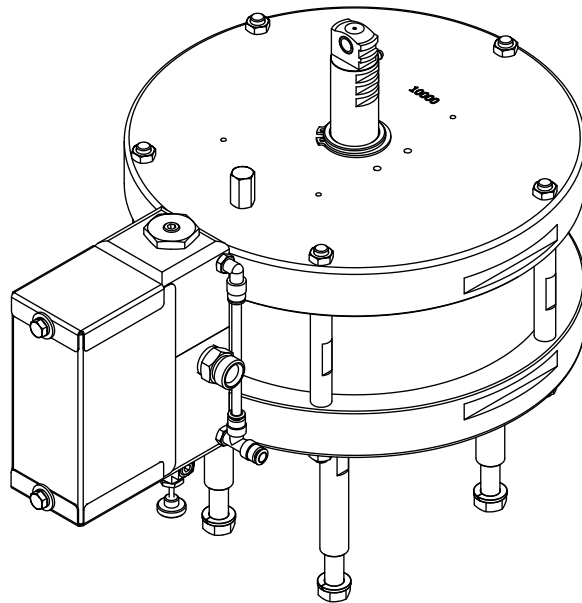

MAGNUM VENUS PRODUCTS

10" PATRIOT POWER HEAD

PAT-PH-10000