

NOTE: A LIGHT COAT OF SUPER O LUBE  
IS RECOMMENDED ON THE UPPER  
AND LOWER PILOT VALVES

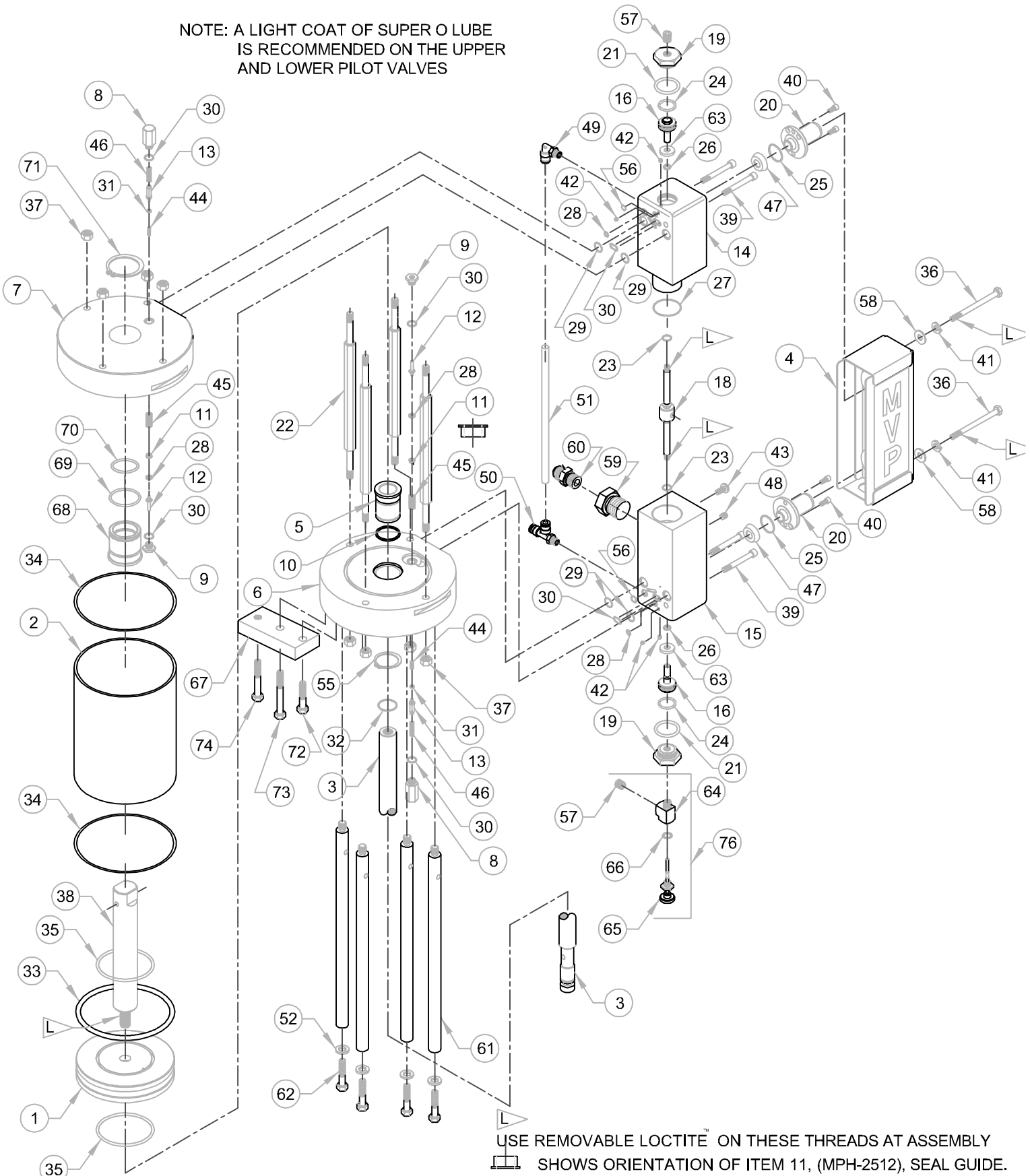

# MAGNUM VENUS PLASTECH

Assembly - 5" Power Head - Slave Arm Top VPH-5000-P

REV F = ITEM 51 WAS 01417 11/09/07 BT2  
 G = ADDED SUPER O LUBE NOTE FOR PILOT VALVES 05/25/11 BT2  
 H = CORRECTED ID BUBBLE FOR ITEMS 63 AND 71 03/02/17 BT2  
 I = ORIENTED MUFFLER FOR DOWNWARD EXHAUST 02/23/18 BT2

# Assembly - 5" Power Head - Slave Arm Top VPH-5000-P

## PARTS LIST

ITEM	PART NO.	QTY	DESCRIPTION
1	MPH-5006	1	PISTON - 5" PUMP
2	VPH-5002	1	CYLINDER - 5" PUMP X 4" STROKE
3	VPH-4259	1	PISTON ROD
4	VPH-5004-01	1	MUFFLER ASSY - 4" STROKE PUMP
5	VPH-4254	1	PISTON ROD BUSHING
6	VPH-5008	1	LOWER ENDCAP - 5" PUMP
7	VPH-5007	1	UPPER ENDCAP - 5" PUMP
8	MPH-2541	2	INLET SPRING HOUSING - PILOT VALVE
9	MPH-2511-01	2	ASSY - STEM SEAL
* 10	O-B-121	1	O-RING
11	MPH-2512	2	SEAL GUIDE
12	MPH-2513	2	VALVE STEM - PILOT VALVE
13	MPH-2540	2	INLET ROD - PILOT VALVE
14	VPH-5001	1	UPPER VALVE BLOCK - 4" STROKE PUMP
15	MPH-5001	1	LOWER VALVE BLOCK
16	MPH-2517	2	VALVE PISTON
18	VPH-5005	1	VALVE POPPET
19	MPH-2521	2	VALVE END CAP
20	MPH-5009	2	VALVE EXHAUST
* 21	O-B-019	2	O-RING
22	VPH-5003	4	TIE ROD 4" STROKE PUMP
* 23	O-U-206-90	2	O-RING
* 24	O-B-116	2	O-RING
* 25	O-B-026	2	O-RING
* 26	O-D-010-90	2	O-RING
* 27	O-B-125	1	O-RING
* 28	O-B-008	4	O-RING
* 29	O-B-014	4	O-RING
* 30	O-B-012	6	O-RING
* 31	O-U-006	2	O-RING
* 32	O-B-118	1	O-RING
* 33	O-B-425	1	O-RING
* 34	O-B-159	2	O-RING
* 35	O-B-415	2	O-RING
36	F-HB-04C-56-SS	2	HEX HEAD CAP SCREW
37	F-HN-06F	8	HEX NUT
38	VPH-7004	1	UPPER PISTON ROD
39	F-CS-04C-40-SS	4	SOCKET HEAD CAP SCREW
40	F-CS-04C-08-SS	4	SOCKET HEAD CAP SCREW
41	F-SW-04-SS	2	LOCK WASHER
42	F-SS-832-02-SS	4	CUP POINT SET SCREW
43	F-BHCS-04C-16-SS	1	BUTTON HEAD CAP SCREW
44	MPH-2526	2	SPRING
45	MPH-2528	2	SPRING
46	MPH-2533	2	SPRING
* 47	MPH-5010	2	DIAPHRAGM
48	PF-AP-04-SS	1	PIPE PLUG
49	MPH-2539	1	PUSH POLY FITTING - MALE ELBOW
50	MPH-2538	1	PUSH POLY FITTING - MALE TEE
51	MS-2052-1	.56ft	Ø1/4 x 6-3/4 POLY TUBING
52	F-SW-06	4	LOCK WASHER
55	MPH-3261	1	SNAP - RING
* 56	O-B-011	2	O-RING
57	PF-AP-02-SS	2	PIPE PLUG
58	F-FW-04	2	FLAT WASHER
59	PF-RB-08-06	1	PIPE BUSHING
60	PF-HN-06-06S	1	ADAPTER
61	2104-4-1	4	TIE ROD
62	F-HB-06C-24-GR8	4	GRADE 8 HEX CAP SCREW
63	MPH-3262	2	PISTON STOP
64	00276	1	TEE FITTING

## PARTS LIST

ITEM	PART NO.	QTY	DESCRIPTION
65	MPH-2546-01	1	VALVE STEM
66	MPH-2545	1	SEAL
67	VPH-7006	1	MOUNT BLOCK
68	VPH-7005	1	BUSHING
* 69	O-B-127	1	O-RING
* 70	O-B-124	1	O-RING
71	7205-2-6	1	SNAP RING
72	F-HB-06C-20	1	HEX CAP SCREW
73	F-HB-06C-40	1	HEX CAP SCREW
74	F-HB-06C-32	1	HEX CAP SCREW
75	DONOTOILAI RMOTOR	1	DO NOT OIL DECAL (NOT SHOWN)

## OPTIONAL PARTS AND ASSEMBLIES

### PARTS LIST

ITEM	PART NO.	QTY	DESCRIPTION
76	MPH-2542	1	RESET BUTTON ASSY
	VPH-SB-XL	1	SHIFT BLOCK ASSY

\* COMPONENTS INCLUDED WITH SEAL KIT.

## REPAIR KITS

PART NO. DESCRIPTION

\* VPH-5000-P-SK SEAL KIT

FIGURE 1-1

